



**Platform–train interface for
rail passengers – a
technology review**



An Australian Government Initiative



DOCUMENT CONTROL SHEET

CRC for Rail Innovation Old Central Station, 290 Ann St, Brisbane QLD 4000 GPO Box 1422 Brisbane Qld 4001 Tel: +61 7 3221 2536 Fax: +61 7 3235 2987 www.railcrc.net.au	Document: Final report
	Title: Platform–train interface for rail passengers – technology review Project Leader: Dr Dhamodharan Raman Authors: Rajkumar Devadoss, Shan Sanjar Ahmad and Dr Dhamodharan Raman Project no: R3.115 Project name: Platform access

Synopsis: The main purpose of this report is to review the solutions available in the public domain to address the platform gap issues of passenger rail operations in Australia. Passengers, in particular passengers with reduced mobility (including the disabled and aged people), experience difficulties in accessing railway platforms primarily due to the lack of suitable technologies or to the intrinsic design limits of platforms and rolling stock. A feasible, robust and cost-effective engineering solution is required to overcome this critical platform access issue. Various patented solutions and other solutions that are used worldwide are discussed briefly in the report. In addition, a couple of new solutions are designed and suggested in the report.

Considering the lack of detailed information about the existing solutions, a basic qualitative analysis was conducted to rank the solutions. This analysis was conducted with respect to various factors, including costs involved, ease of implementation, applicability of the solutions for different platform setups, and operational safety.

Most of the solutions discussed in the report are designed for high level platforms, and only cater for horizontal gaps. Therefore, when ranking the solutions, more weight was given to solutions that catered for both high and low level platforms, as well as straight and curved platforms. The possible future research direction that might help address the gap-closing issues in the Australian rail network environment is also discussed in the report.

REVISION/CHECKING HISTORY

REVISION NUMBER	DATE	ACADEMIC REVIEW (PROGRAM LEADER)	INDUSTRY REVIEW (PROJECT CHAIR)	APPROVAL (RESEARCH DIRECTOR)
0				

DISTRIBUTION

DESTINATION	REVISION										
	0	1	2	3	4	5	6	7	8	9	10
Industry participant for review	X										

Copyright © 2012

This work is copyright. Apart from any use permitted under the *Copyright Act 1968*, no part may be reproduced by any process, nor may any other exclusive right be exercised, without the permission of Central Queensland University.

TABLE OF CONTENTS

List of figures **iii**
List of tables **iii**

1. Introduction **1**
 1.1 Project aims and objectives 2

2. Background study on platform gap issues **3**
 2.1 Accessibility standards 4
 2.1.1 Australia 4
 2.3.2 United States 4
 2.3.3 Europe 5
 2.2 Platform gaps in Australia 5
 2.3 Factors affecting platform-to-train gaps 5

3. Platform gap-closing solutions – a review **8**
 3.1 Patented solutions 8
 3.1.1 Platform edge warning ramp 8
 3.1.2 Train-to-platform gap mitigator 9
 3.1.3 Step apparatus for platform 10
 3.1.4 Railway platform gap filler 11
 3.1.5 Gap-bridging device for train platforms 12
 3.1.6 Automatic gap filler 13
 3.1.7 Train car compensator 14
 3.1.8 Gap-bridging device 15
 3.1.9 Safety gap filler 15
 3.1.10 Retractable station platform extension 16
 3.2 Existing gap-closing solutions used in different railway systems 18
 3.2.1 Platform edge extender 18
 3.2.2 Movable platform edge 20
 3.2.3 Automatic gap filler 20
 3.2.4 Extended rubber finger 21
 3.2.5 Rubberised on-board gap filler 21
 3.2.6 Power bridge plate 21
 3.2.7 Westinghouse platform screen door gap filler 22
 3.2.8 Matangi on-board ramp 22
 3.2.9 Glidelok ramp 22
 3.2.10 Interchangeable step design 23

3.2.11 Corrugated platform edge	24
3.3 Supporting devices for platform gap fillers	24
3.3.1 CACOLAC automatic gap filler controller device	24
3.3.2 Platform screen doors	25
3.3.3 Devices to open and close platform screen doors	25
3.4 Proposed new solutions	26
3.4.1 Movable platform steps.....	26
3.4.2 Movable platform ramp.....	27
3.4.3 Movable on-board steps.....	27
3.4.4 Hinged on-board ramp	28
3.4.5 Smaller wheels.....	29
3.4.6 Use of parallel tracks	29
3.5 Gap mitigation by existing solutions.....	30
3.5.1 Platform-based solutions.....	30
3.5.2 Rolling stock-based solutions	30
4. Qualitative assessment of solutions.....	33
4.1 Parameters for qualitative assessment	34
4.1.1 Cost	34
4.1.2 Implementation	34
4.1.3 Applicability	34
4.1.4 Operations	34
4.2 Weighting of criteria	35
4.3 Ranking of solutions.....	35
4.4 Discussion	35
4.4.1 Ranking based on cost	35
4.4.2 Ranking based on implementation.....	36
4.4.3 Ranking based on applicability	36
4.4.4 Ranking based on operations	37
4.4.5 Overall ranking.....	37
5. Discussion and recommendations	43
References.....	44
Appendix 1 – Ranking based on cost.....	46
Appendix 2 – Ranking based on implementation	47
Appendix 3 – Ranking based on applicability	48
Appendix 4 – Ranking based on operations	49
Appendix 5 – Overall ranking	50

LIST OF FIGURES

Figure 1 Horizontal and vertical gaps 3

Figure 2 Results of field study..... 4

Figure 3 Rail-to-platform measurements 7

Figure 4 Platform edge warning ramp..... 9

Figure 5 Train-to-platform gap mitigator 9

Figure 6 Stepped gap filler..... 10

Figure 7 Sliding gap filler 10

Figure 8 Step apparatus for platform 11

Figure 9 Operation of step on straight and curved platforms..... 11

Figure 10 Railway platform gap filler..... 12

Figure 11 Gap-bridging device for train platform..... 13

Figure 12 Automatic gap filler 13

Figure 13 Automation of gap filler..... 14

Figure 14 Train car compensator..... 14

Figure 15 Gap-bridging device between a platform and a train 15

Figure 16 Safety gap filler 16

Figure 17 Alternative design for safety gap filler 16

Figure 18 Top view of retractable station platform extension..... 17

Figure 19 Side view of retractable station platform extension 17

Figure 20 Platform edge extender at 14th Street, New York 19

Figure 21 Platform gap filler, Hong Kong..... 19

Figure 22 Platform edge extender at South Ferry, USA 19

Figure 23 Movable platform edge 20

Figure 24 Automatic gap filler 20

Figure 25 Extended rubber fingers 21

Figure 26 Rubberised gap filler added to a train..... 21

Figure 27 Westinghouse platform screen door gap filler..... 22

Figure 28 Matangi manually deployed on-board ramp..... 22

Figure 29 Glidelok ramp 23

Figure 30 Interchangeable step design..... 23

Figure 31 Corrugated platform edge 24

Figure 32 CACOLAC system..... 25

Figure 33 Platform screen door..... 25

Figure 34 Illustration of movable platform steps 26

Figure 35 Illustration of movable platform ramp 27

Figure 36 Illustration of movable on-board steps 28

Figure 37 Illustration of hinged on-board ramp 29

Figure 38 Illustration of use of parallel tracks 29

Figure 39 Solutions to mitigate the train-to-platform gap..... 32

Figure 40 Parameters identified for qualitative assessment..... 33

LIST OF TABLES

Table 1 Existing gap-closing solutions from different railways 18

Table 2 Rating of different parameters for qualitative assessment..... 38

Table 3 Qualitative assessment 40

1. Introduction

A railway platform is a segment of pathway beside rail tracks at a train station, from which passengers board or alight from carriages. The train station and its platform are the first point of contact the passengers have with the railway. Platforms should be well designed, comfortable, convenient and safe for passengers. However, passengers confront practical difficulties in accessing these platforms, primarily due to the lack of suitable technologies or to the intrinsic design limits of the platforms and rolling stock. To be more specific, passengers are faced with less than ideal access to carriages due to wide horizontal and vertical gaps between platforms and trains. This is particularly exacerbated for people with reduced mobility, including disabled people and elderly passengers. In Australia, nearly half a million people with a disability in some form find it difficult to get in or out of carriages due to steps, doors and other reasons (Australian Bureau of Statistics 2003). This gap increases in a curved platform, making access difficult even for able-bodied passengers. This results in poor customer service outcomes, as well as poor accessibility between train and platform for people with special needs. Ideally there should be no gap between platforms and trains, but practically this is not possible, as platforms are designed to safety standards which demand a clearance between train and platform. In addition to the platform design factors, rolling stock and track-related factors also contribute to the platform gap.

The gap between train and platform has been found to be a major cause of fatality in railway stations since the beginning of passenger railways. Researchers around the world are trying to minimise the rate of casualties at railway stations by providing gap-closing solutions. Research by Atkins Rail (2004) reports that there seems to be limited scope in moving the platform or modifying the vehicle dimensions to reduce the gap.

The height of a platform can be expressed through two measurements: train platform height and train floor height. Earlier platforms were constructed at the same level as the track, which resulted in a significant height difference between the platform and the train floor. The passengers were forced to climb up into trains, usually with the help of supporting staff and portable steps carried on vehicles. The next stages of platform design had an elevated level relative to the track, but still often lower than the train floor, irrespective of the fact that an ideal platform should be at the same level as the train floor. This platform gap is causing a serious access issue for passengers, in particular passengers with various disabilities, or with wheelchairs and strollers. The access issue gets complicated if different types of trains with varying train floor levels are accessing a platform with a fixed height level.

In addition to height, other factors that significantly affect effective and safe platform access are:

- **platform width** — sufficient to permit free unhampered movement of passengers
- **platform length** — adequate to accommodate the longest train serviced at that station
- **platform surface** — designed to have some form of warnings or measures to keep passengers away from tracks and moving trains (e.g. special tiled surface to alert blind people about their position relative to the platform edge, or a slope upwards towards the edge to prevent wheeled objects from accidentally rolling very near the platform edge).

As per the federal Disability Standards for Accessible Public Transport (DSAPT) (2002), a vertical gap of 15 mm and horizontal gap of 40 mm requires no additional assistance. The current Australian platform standards and designs do not satisfy the DSAPT requirements. To overcome this issue, some of the rail network owners have provided a manually deployed bridging ramp to comply with the requirements (Ryan et al. 2009). Manually deployed bridging plates and ramps do not always provide good stability while boarding and alighting. Passengers find it difficult, particularly when alighting from a train, to do so independently (Bradshaw 2008). Manually deployed bridging plates make it much more difficult to board and alight independently on low level platforms (850 mm above rail surface) with a grade of 1:5 and a ramp length of 1520 mm. One of the straightforward methods to address this issue is to modify or rebuild all the existing platforms to a high level platform (1050 mm above rail surface), which provides a theoretical gap of 55 mm vertically and 100 mm horizontally on a straight platform. On curved platforms, the Queensland Rail network (Ryan et al. 2009) proposes to limit the horizontal gap to 120 mm. In an initial assessment of high level platforms, Ryan et al. (2009) report that the horizontal and vertical gaps varied between 45–170 mm and 0–110 mm respectively, and the variations are due to train, track, platform

tolerances, cant, end throw and centre throw for straight and curved platforms. Most of the platforms in Australia are low level platforms. To change or modify all the platforms is a costly process, and has practical limitations, as pointed out by Stephensen (1994), in that coal wagons passing through these stations may hit a high level platform. Therefore, the requirement is a practicable gap-closing solution for all platforms to comply with the DSAPT requirements.

This report reviews the solutions that are available around the world for this critical platform gap issue. Existing patents for gap-closing solutions are reviewed. This report will also introduce the various factors that contribute to the gap between the platform and the train, and identify the most influential factors (discussed in section 2.3). Considering the limitations in accessing detailed information about the solutions, a qualitative assessment was performed on the identified solutions, ranking them with respect to the following criteria:

- cost
- implementation time
- complexity
- applicability for different types of platform
- operational aspects/constraints.

The report then recommends the possible cost-effective solutions suitable for the Australian passenger network. At the same time, it should be noted that these recommendations are very generic, as there was no quantitative information about current platform gap issues across Australia. In addition, such detailed analysis is beyond the scope of this project. However, the findings of this current project will act as a vital source of information for the future larger sequel project, which is mandatory to develop, identify and deploy solutions that are more specific to the platform access issues existing in Australia.

1.1 Project aims and objectives

The aim of the current review project is to recognise practicable gap-closing solutions for independent access to trains from platforms for all passengers, and where appropriate, to propose methods to address these issues in passenger operators around Australia. The objectives that have been identified to achieve this research aim are:

- review, recognise and characterise the different gap-closing solutions used around the world
- suggest cost-effective and reasonably practicable solutions through a review of solutions that exists across the world in patents, other systems and in parallel industries (e.g. airport transit systems). The potential solutions may include modifications to one or all of track, train or platform
- conduct a qualitative assessment of all solutions
- identify and suggest alternatives that could create new technologies to solve access issues for stations and carriages.

2. Background study on platform gap issues

The gap between the train and platform is expressed as vertical and horizontal gaps, as shown in Figure 1. The horizontal gap is measured from the platform vertical edge to the front face of the tread plate. The vertical gap is measured from the platform horizontal edge to the top face of the tread plate. These gaps are influenced by platform construction, tolerances, movement of the track and the type of train in operation. Even though these gaps are not desired, it is not practicable to attain a zero gap. A certain clearance should be included in the platform design to accommodate for variations in track and train to avoid moving trains hitting the platform. Since the gaps are unavoidable, the following two tasks are essential to mitigate this platform gap issue:

- Firstly, it is very important to know the optimum gap for easy access by passengers.
- Secondly, suitable gap-closing solutions should be deployed into the platform system.

Figure 1: Horizontal and vertical gaps

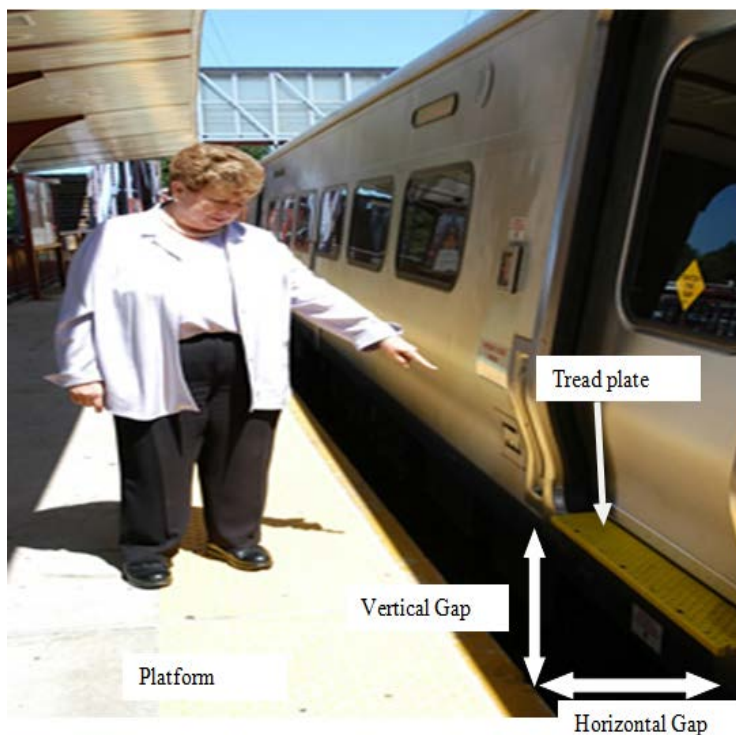

(Image courtesy: <http://www.transitblogger.com/system-conditions/yet-another-lirr-gap-accident.php>)

There has been much research and field study done to find out the acceptable gap settings for different kinds of passengers. In a field study by Atkins Rail (2004) for the Significant Steps project, 120 people, including people with disabilities and people without disabilities, were used in the study to board and alight with different gap settings. The study finally concluded that the acceptable stepping distance parameter (when the step height from the platform and the gap width are added together — H+V) should not exceed 200 mm, and that a stepping distance of 300 mm is unacceptable, as shown in Figure 2.

Figure 2: Results of field study

		Gap Width – Horizontal Distance between platform and train									
		50	100	150	200	250	300	350	400	450	500
	Level		n=12 t=3.3 s=8% e=0% dnc=0		n=15 t=3.3 s=7% e=13% dnc=1		n=53 t=4.9 s=38% e=17% dnc=0				
Step up into train or step down out of train	-50			n=50 t=3.0 s=4% e=4% dnc=1		n=5 t=4.4 s=20% e=0% dnc=0					
	-100		n=7 t=4.0 s=14% e=0% dnc=0								
	-150	n=40 t=3.8 s=5% e=5% dnc=0		n=9 t=7.0 s=22% e=0% dnc=0			n=49 t=4.7 s=37% e=10% dnc=3				
	-200				n=6 t=3.9 s=33% e=0% dnc=0	n=5 t=5.4 s=20% e=20% dnc=0					
	-250		n=8 t=8.0 s=63% e=13% dnc=0								
	-300	n=50 t=5.3 s=32% e=12% dnc=2					n=51 t=6.5 s=71% e=29% dnc=7				

Unacceptable Safety and Effort

n = number of participants in the group completing the setting.

t = median time in seconds for the ambulant disabled group to board / alight

s = percentage of participants who felt a little unsafe or worse

e = percentage of participants where exceptional effort was required

dnc = number of participants (additional to n) who attempted but did not complete the setting

(Source: Atkins Rail 2004)

2.1 Accessibility standards

Considering the importance of having optimal platform gaps, several government organisations have developed accessibility standards, and these are discussed below.

2.1.1 Australia

The DSAPT (2002) recommends that, for independent access by disabled passengers, the gap values should be:

- vertical rise or gap below 15 mm (AS3856.1 (1998), Clause 2.1.7 (f))
- horizontal gap below 40 mm (AS3856.1 (1998), Clause 2.1.8 (g)).

2.1.2 United States

According to the Americans with Disability Act (Accessibility Guidelines for Buildings and Facilities), clauses 10.3.1.9 and 10.3.2.4, the vertical gap between vehicle floor and platform should be less than 5/8 of an inch (15.875 mm), and the horizontal gap should be less than 3 inches (76.2 mm) for new constructions. The vertical gap between vehicle floor and platform should be less than 1.5 inches (38.1 mm), and the horizontal gap should be less than 3 inches (76.2mm) for existing constructions.

2.1.3 Europe

The Rail Vehicle Accessibility (Non-Interoperable Rail System) Regulations 2010, under Schedule 1, Part 1.1.2, states that, for wheelchair independent access, the vertical gap should be less than 50 mm and the horizontal gap less than 75mm.

2.2 Platform gaps in Australia

This section reviews the gaps between platforms and trains in Australia. The passenger network and its design parameters vary significantly across Australia as they were built individually by state governments. In Queensland, the horizontal and vertical gaps on new high level platforms (1050 mm from rail surface) are 100 mm and 50 mm respectively, and the horizontal and vertical gaps on old standard low level platforms (810 mm from rail surface) are 0 mm and 290 mm respectively. Most high and low level platforms in Australia do not comply with the DSPAT requirements.

2.3 Factors affecting platform-to-train gaps

In order to effectively address the platform gap issues, it is essential to study and analyse the factors that determine the gap and its dimensions. The various factors identified by Significant Steps research (Atkins Rail 2004) are briefly discussed here.

Step height

Step height is the distance between the tread plate and the platform measured vertically from the platform to the top of the tread plate. Generally, vehicle floor heights are kept higher than platforms for safety margins that can accommodate variances in platform heights due to vehicle suspension displacements. This particular factor can be further explored in order to reduce the gap in terms of step height distance.

Step thickness

Step thickness has an effect if the gap is measured from the bottom of the tread plate. However, this factor is not an influential one, as the vertical gap is measured to the top of the tread plate.

Train floor height

Train floor height is one of the important factors, as the tread plate placement is in relation to the floor height. This has a major effect on the gap between the train and the platform. Optimisation of the train floor height can be helpful in reducing the vertical gap between train and platform.

Suspension displacement

The kind of suspension used to absorb or isolate the vibration and impact loads from the wheel–rail interface also plays an important role. The softer the suspension, the more vertical displacement the vehicle will experience on the train load. The train-to-platform gap can be reduced by optimising the suspension system without sacrificing customer comfort.

Inflated/deflated secondary suspension displacement

There will be a difference in the floor height dependent on when the secondary suspension is inflated (normal running) and deflated (defective). A worn or defective suspension will result in the train being lower, providing a shorter vertical stepping distance. Even though the shorter vertical stepping distance is good for ingress and egress, defective suspension is not good for ride quality.

Wheel size

The smaller the diameter of the vehicle's wheels, the lower it will ride, providing a shorter stepping distance, assuming that the train floor is above platform height. Smaller wheels will result in quicker wear (as there are more revolutions).

Platform heights

The low level platform height is 810 mm (Stephensen 1994). The new high level platform height is 1050 mm — the lower the platform, the greater the stepping distance. Existing EMU trains have a tread plate height of 1100 mm, and considering tolerances, wear and track settlement, the platform will always be slightly lower than the tread plate for consistent access of passengers (Stephensen 1994).

Rail to platform distance

The standard minimum horizontal distance between the centreline of the track and the platform is 1550 mm (Stephensen 1994). If this distance is greater, then the stepping distance is greater. This is known as the offset of the platform. A greater offset may be required to allow rolling stock to pass the platform at high speed. If all rolling stock using the line stopped at the station, it may be possible to provide a smaller offset.

Radius of track at platform

The greater the radius of curvature of the track, the more the train is 'thrown' off its centreline (curvature is measured as a radius from the theoretical centre of the arc). When considered alongside the door position, the stepping distance can be greater on convex curved platforms when the doors are at the vehicle ends (outboard), and on concave platforms when the doors are towards the centre of the vehicle (inboard).

Line speed at platform

The greater the speed that trains are permitted to travel, the greater the vehicle sway from the centreline. Therefore, at platforms where trains are permitted to pass at high speed, allowance has to be made for greater vehicle sway, meaning that the platform edge has to be further back, resulting in a greater stepping distance.

Position of doorway relative to bogies

When trains travel around curves, the ends and the centre of the trains are 'thrown' outside the track centreline. The same is true if the train is stationary at a curved platform. The position of the train doors will impact on the

stepping distance. To achieve the best compromise, it is preferable for the doors to be over the bogies (wheels). The amount of throw that the vehicle experiences at the doorway affects the stepping distance.

Vehicle length

The longer the vehicle, the greater the potential for being ‘thrown’ off the centreline as it goes around a bend.

Installed cant

Track cant is applied to permit trains to travel around curves at higher speeds. The amount of installed cant is a function of the curvature of the track and the line speed. Cant is the difference in height between two rails on the track, as shown in Figure 3. Installed cant will have the effect of leaning the train towards a convex platform, reducing stepping distances, or away from a concave platform, increasing stepping distances.

Figure 3: Rail-to-platform measurements

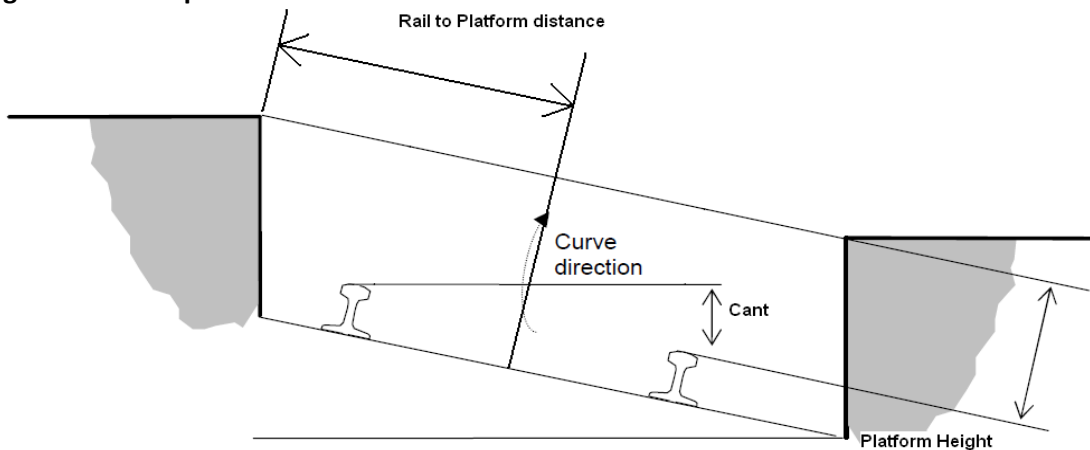

Fixity of track

Fixity refers to the amount that the track is allowed to move relative to the ground, and ultimately affects the position of the train with respect to the platform edge. For the QR network, the tolerance for the horizontal movement of the track is 57 mm. Different designs of track will allow for different levels of fixity. A higher level of fixity means potential to improve stepping distances, as a lower safety margin is required and vehicle sway is reduced.

3. Platform gap-closing solutions – a review

Inherent platform gaps cause accessibility issues, not only for disabled passengers, but also for able-bodied passengers. Depending on the dimensions of the gap and the availability of supports or devices to bridge this gap, access issues are categorised into three levels:

- restricted access — most people, including disabled passengers, cannot access due to lack of any gap-closing device, which results in an inadequate level of access
- dependent access — many people, including disabled passengers, can access due to the supply of special devices, which results in a medium level of access
- independent access — most people, including disabled passengers, can access due to the supply of mainstream gap-closing solutions, which results in a high level of access.

Rail operators prefer to reduce the platform gap and ensure independent access for their passengers by deploying effective gap-closing solutions. Various solutions have been reviewed in this project, categorised into two types discussed in this chapter:

- patented solutions
- implemented solutions.

Emphasis has been given to those patented solutions that can be directly applied to existing platforms. Additional equipment is necessary to enable some gap-closing solutions to run automatically and effectively. Such commercially available accessories also are discussed in this report.

3.1 Patented solutions

3.1.1 Platform edge warning ramp (Hanrahan, Keegan & Goffe 1995)

A stationary ramp is positioned at the edge of the platform to provide stable access to the train. The system comprises an inclined supporting surface extending over a portion of a train platform edge to a predetermined distance from the platform edge. The first longitudinal edge of the device (Figure 4) can be raised or lowered by an adjustable bolt. The adjustment reduces the horizontal and vertical gap to some extent.

The varying thicknesses of the rectangular platform surface make a different sound when hit by a footstep or stick of a passenger moving towards the train. Vision impaired passengers can detect their position by the difference in sound.

A platform edge warning ramp provides a stable raising platform with predetermined gap-closing distances. The change in adjustment requires manual operation that can be automated by an electric motor. However, the adjustment can take time if the station faces trains with different height and width of tread plate, which may delay train operations. The inherent warning principle will help increase passenger safety, in particular for passengers with vision impairment.

Figure 4: Platform edge warning ramp

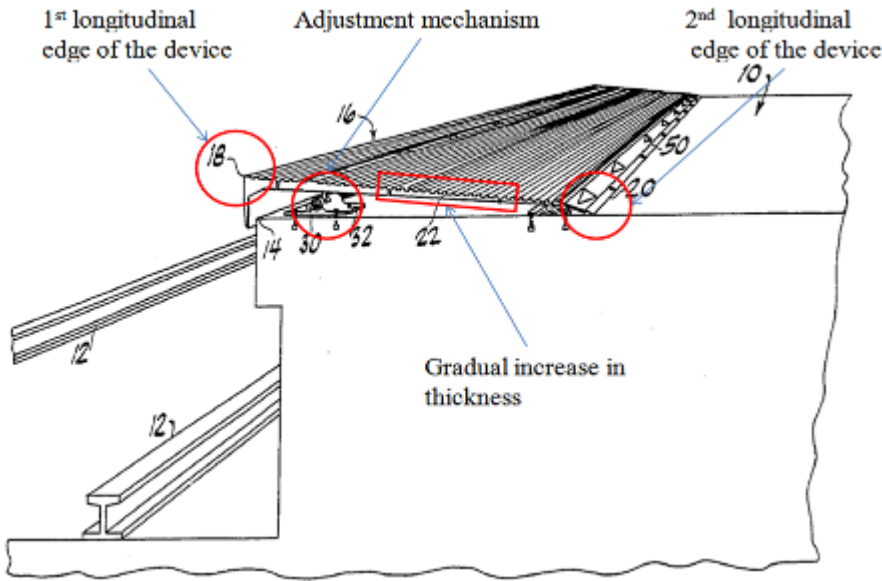

(Source: Hanrahan, Keegan & Goffe 1995)

3.1.2 Train-to-platform gap mitigator (Chisena 2008)

In this invention, different gap filling mechanisms from train to platform have been proposed. When a train reaches the platform, a computer program will determine the required gap-filling method, based on the available data from the platform and information sensors. Different gap-filling mechanisms like stepped (Figure 6) and sliding (Figure 7) from the train will facilitate the appropriate gap-filling methods for a wide range of variation in horizontal and vertical gaps on both tangent and curved track.

Figure 5: Train-to-platform gap mitigator

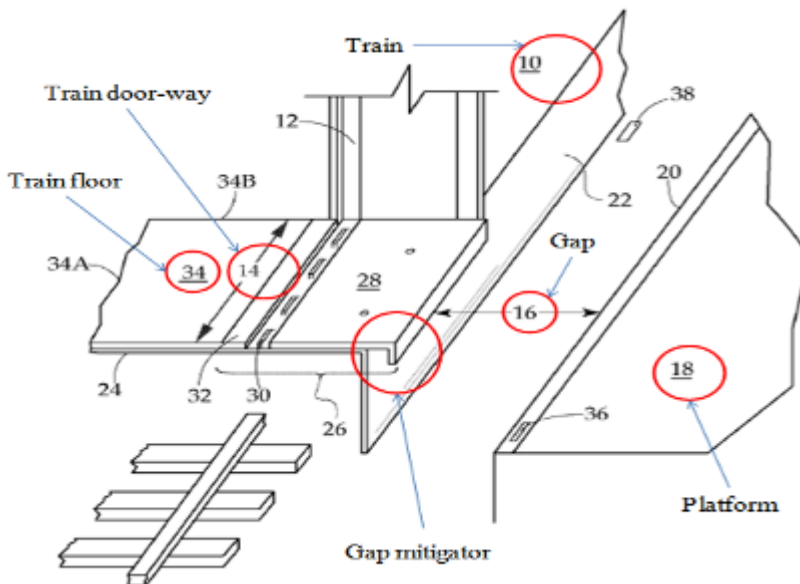

(Source: Chisena 2008)

Figure 6: Stepped gap filler

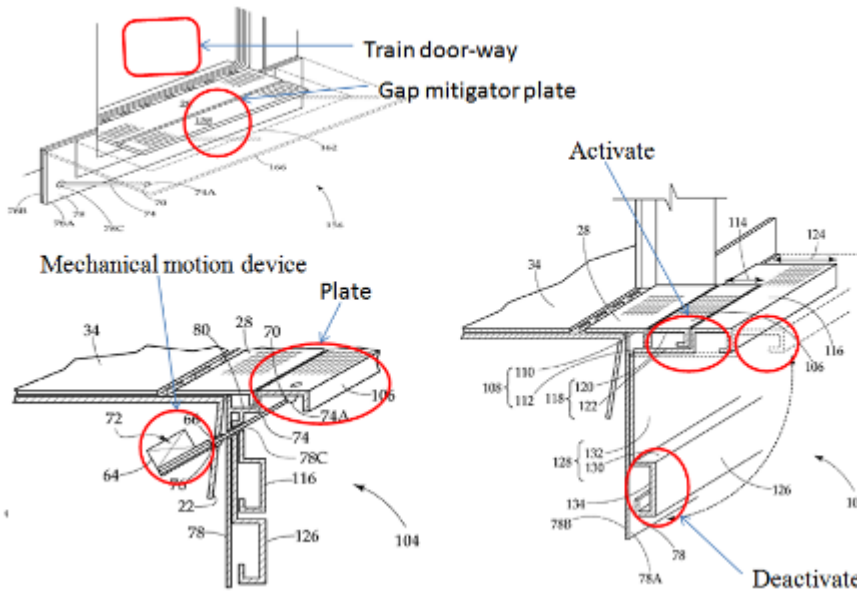

(Source: Chisena 2008)

This method is suitable for different scenarios, but is expensive in terms of upgrading all trains in the network. The preloaded information of all stations in a computer program will help to reduce the time delay on platforms for adjusting the gap by actuating the device when a train is close to a particular station. The actuator devices require regular inspection. A fault in the computer program will require skilled personnel to fix.

Figure 7: Sliding gap filler

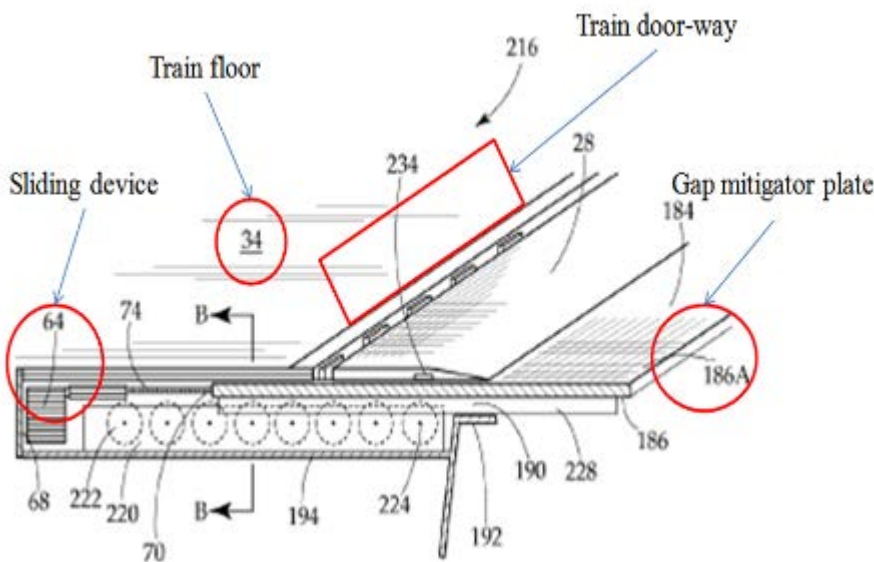

(Source: Chisena 2008)

3.1.3 Step apparatus for platform (Yamaguchi et al. 2001)

A simple horizontal step has been proposed for installation on train platforms that can be operated by a rotary shaft and rotating mechanism. The step has also been equipped with sensors to detect the train position and deactivate accordingly (Figure 8). The arm used to connect the step with the rotating mechanism can be changed to meet the required pattern of the station and train. The size and shape of the step can be modified to meet the required conditions. A cover has been proposed for the rotating mechanism to ensure the safety of passengers.

This apparatus can be easily installed on any existing platform, which may reduce costs. Flexibility in providing alignment with the train has made this technique suitable for both straight and curved platforms (Figure 9).

Figure 8: Step apparatus for platform

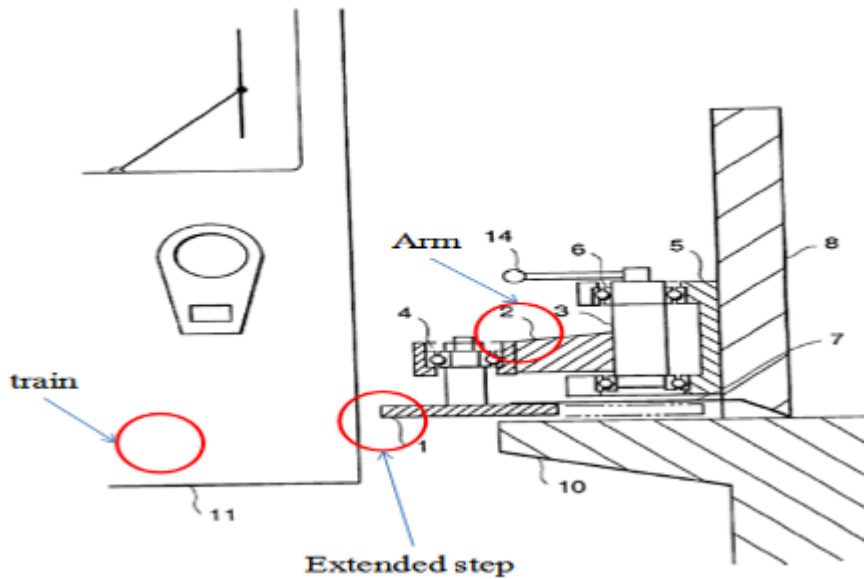

(Source: Yamaguchi et al. 2001)

Figure 9: Operation of step on straight and curved platforms

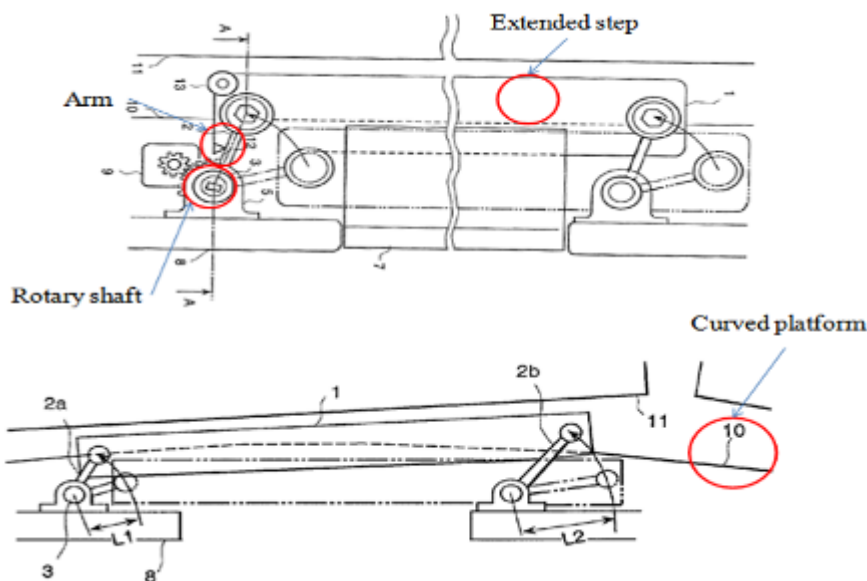

(Source: Yamaguchi et al. 2001)

3.1.4 Railway platform gap filler (Muller 1998)

Flexible sheet-like members are installed with the vertical edge of the platform. The flexible members are installed bent towards the track (Figure 10) to effectively fill the gap between station and train. When a train approaches, the flexible gap-filling members are dynamically bent by the contact of the train, so no manual operation is necessary to activate the gap-closing mechanism. The contact with the platform has been designed as a key slot method, which facilitates easy removal and replacement of gap-filling members if any fault occurs. The bending members can be a one-sheet piece, or two members joined by a resilient material in the bending area near the platform. An alternative to the bending concept is a hinged support at the platform, which may also be adopted. The selection of material and length of the gap-filling members should be such that they are safe

enough to bend, carry the weight of passengers, and provide a satisfactory flat contact between platform and train door.

Figure 10: Railway platform gap filler

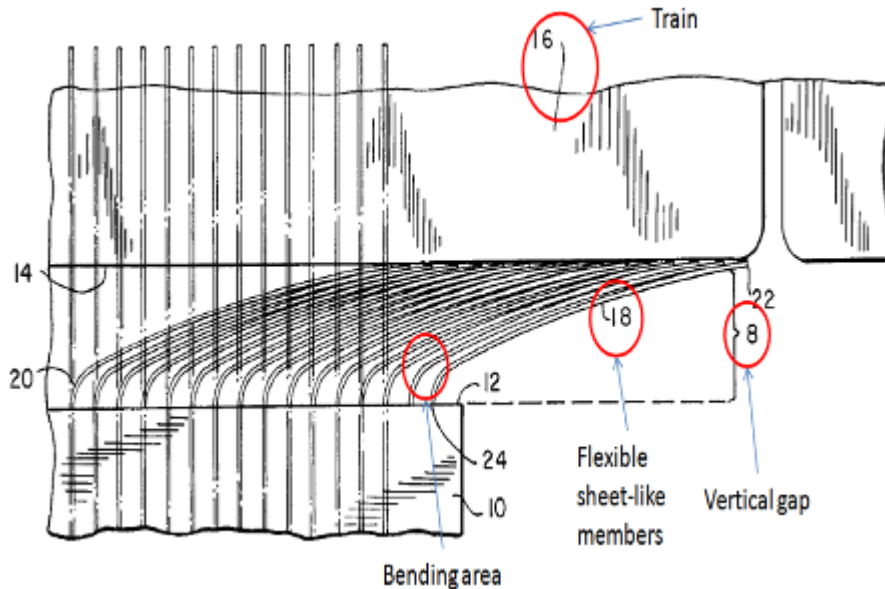

(Source: Muller 1998)

This method is easy to install and maintain, provided the required gap-filling members are well designed. It is expected that data about the distance between platform and track and the nature of the trains passing over that track is known to determine the length of the gap-filling members.

3.1.5 Gap-bridging device for train platforms (Winkelmann & Hug 2010)

A gap-bridging device mounted either to the platform or the train door has been invented. The device consists of an assembly with bridging plate, guide rails, motor, pulley, toothed belts held in a box (Figure 11). The box can be installed on the platform, preferably in a 70 mm recess from the edge of the platform. The motor is used to extract the bridging plate with the help of a timing belt and pulley. The guide rails help the bridging plate to extend uniformly over the length. The bridging plate has been properly reinforced to carry the overhanging loads. The device has an interlocking mechanism which ensures that the bridging plate is locked to a fixed position whenever a passenger load appears over it. Insulation coating has also been advised for the part of the device exposed to passengers to avoid electrification by contact from the train.

Being extended horizontally, the bridge may not be sufficient to minimise the vertical gap in many cases. The activation of the device may delay the train.

Figure 11: Gap-bridging device for train platform

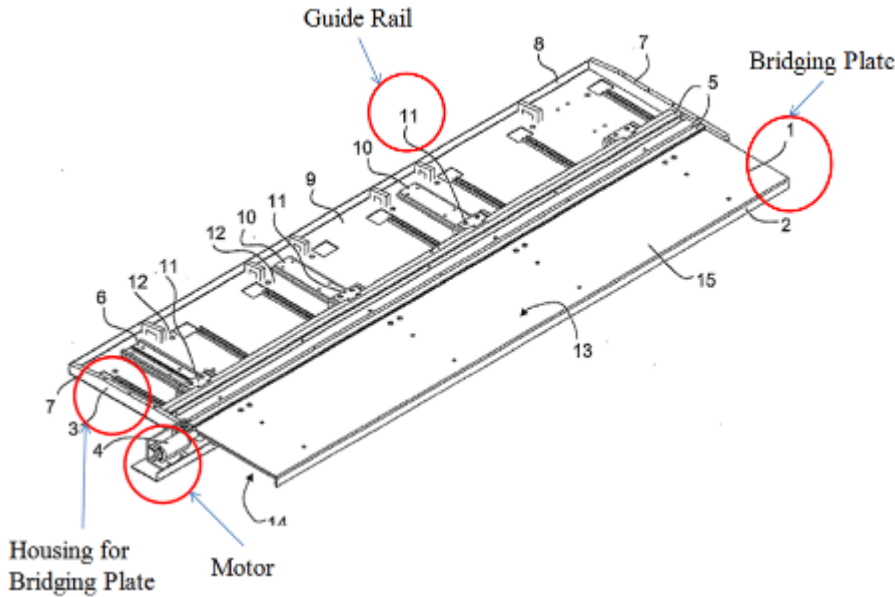

(Source: Winkelmann & Hug 2010)

3.1.6 Automatic gap filler (Vincent-Genod 2003)

Flexible blade members have been proposed for installation on the platform to reduce the gap between platform and train. The gap filler blade has to be placed in a horizontal position, maintaining minimum clearance from the running train (Figure 12). When the train reaches the station, the control system determines the required amount of bending necessary to fill the gap, and the actuator drives the blades to a vertically curved position. The control system (Figure 13) is capable of detecting the position of train stops and controlling the train door operation in conjunction with the actuation of the gap filling device.

This method ensures less wear of the gap filling blades by providing separation between train and gap filler end. It is expected that the gap filler will touch the vehicle only when the vehicle stops, preferably just before the door opens. The gap filling solution can be cost effective if it can be installed near the train doors only. However, in order to install gap filler near the train doors only, the platform should experience representative trains with identical length.

Figure 12: Automatic gap filler

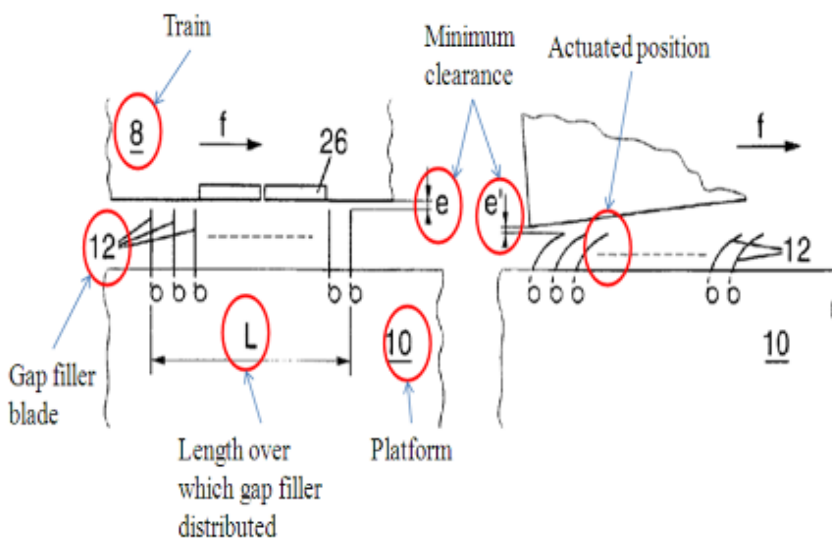

(Source: Vincent-Genod 2003)

Figure 13: Automation of gap filler

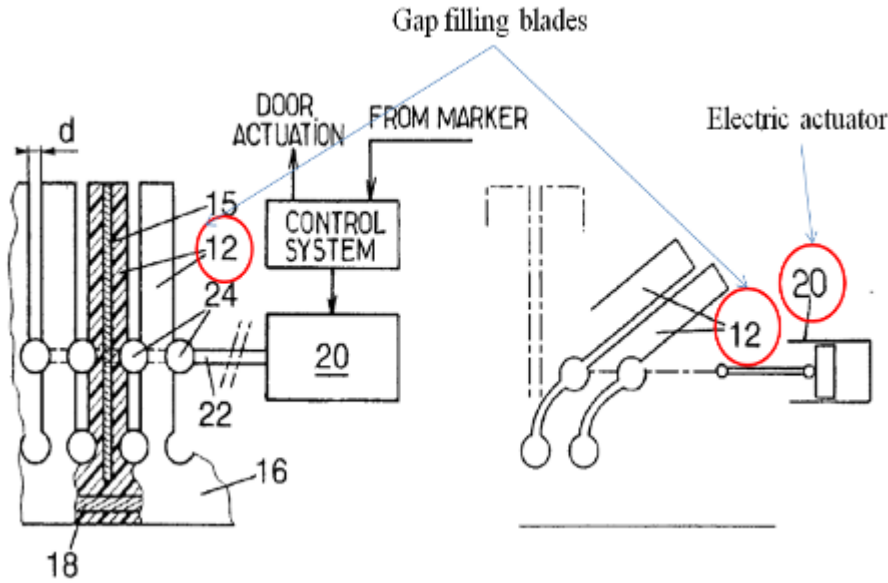

(Source: Vincent-Genod 2003)

3.1.7 Train car compensator (Drago 2008)

The train car compensator needs to be fitted to the train door. The compensator (Figure 14) can slide over the track with the help of a spring or piston; or be pulled down by a cable with a hinge connection. An appropriate electric motor and limit switch can be used to actuate the sliding plate to the required distance.

This technique may not be suitable for curved tracks where the gap varies along the length of the landing plate. This also requires additional time for activating and deactivating the mechanism after the train reaches a station.

Figure 14: Train car compensator

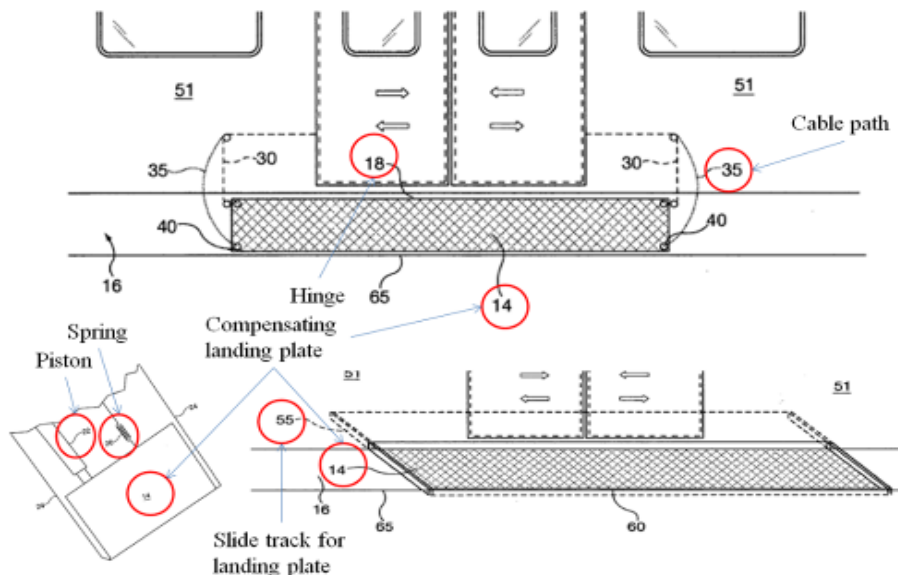

(Source: Drago 2008)

3.1.8 Gap-bridging device (Lomberty et al. 2010)

Segmented bridging gaps have been suggested for installation along the platform at predetermined distances to coincide with train doorways. The bridge comprises stationary and moving parts. The moving part, actuated by an electric motor, fills the gap between the train and platform. Several position-detecting sensors are installed to determine the position of the moving part and control the movement. An electronic control unit (Figure 15) takes a continuous signal from the sensors and sets the required stroke of moving members. It is also possible to keep the required minimum safety gap between train and bridge by pre-programming the controller and calibration. The controller can be actuated either by the station controller or by the operator (e.g. the driver of a train). Gap bridges can be installed at varying lengths to take account of curved platforms. The device may not be adequate to minimise the vertical gap effectively. The control system and sensors require a skilled technician, with related equipment cost. The continuous position detection, while increasing safety by providing accurate gap, may provide unsatisfactory time delay in operation.

Figure 15: Gap-bridging device between platform and train

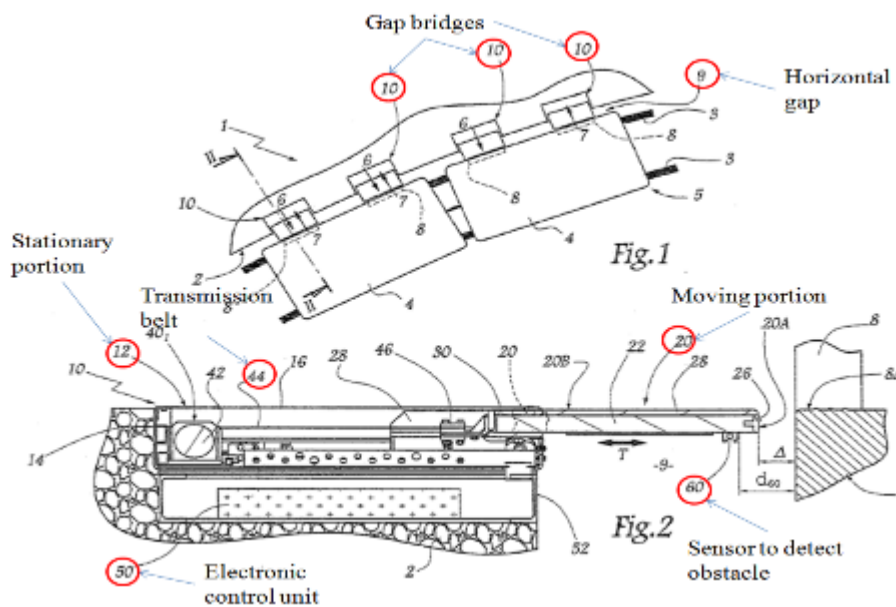

(Source: Lomberty et al. 2010)

3.1.9 Safety gap filler (Lee 2008)

This invention overcomes the disadvantage of commercially available safety gap fillers (discussed in section 3.2.4). The new inclined gap filler reduces the frictional force between the train and gap filler, and ensures more weight-carrying capacity per unit length than the conventional gap filler of the same material. Support bars overhanging from the base body bend towards the direction of train when they come in contact with it, with less friction than the perpendicular arrangement (Figure 16). It also overcomes the disadvantage of the conventional perpendicular design by distributing the gap between support bar in direction perpendicular to passengers' footing and wheels. It is easy to install, with the platform and the material inexpensive compared to other complex methods. In order to accommodate the difference in platform height and gap, an alternative design has been proposed (Figure 17). The support bar can be of different height and length to provide safe vertical and horizontal gaps between train and platform.

Figure 18: Top view of retractable station platform extension

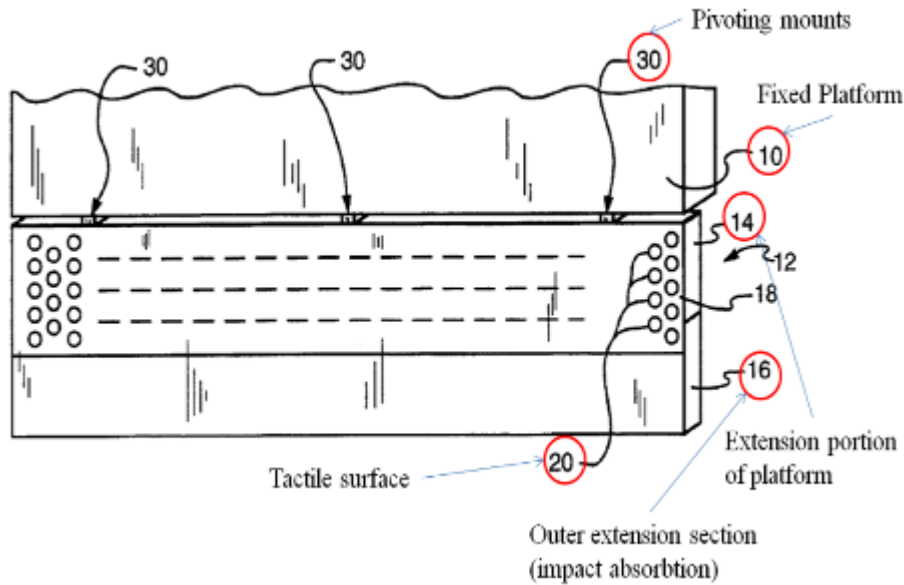

(Source: Klohn 1996)

Figure 19: Side view of retractable station platform extension

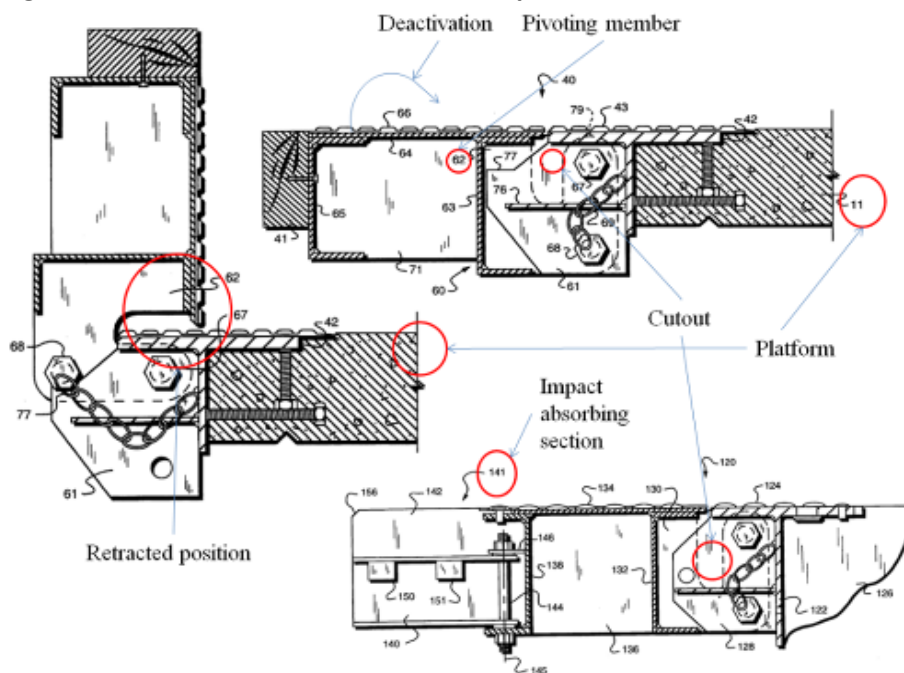

(Source: Klohn 1996)

3.2 Existing gap-closing solutions in different railway systems

Although a number of proposals have been made in different patents, few of them have been implemented around the world to minimise the gap between train and platform. A summary of those solutions which have been implemented is presented in Table 1, and a brief description provided in the following section.

Table 1: Existing gap-closing solutions from different railways

Product	Manufacturer	Application	Web link
Platform gap filler	DRB America	Korea	http://www.drbworld.com/en/pgm/wm02060301.php
	Vulcanite (supplier)		http://www.vulcanite.com.au/project-ref.php
	Westinghouse platform screen door	USA	http://www.platformscreendoors.com/en/products/gapfiller/gapfiller.jsp
CACOLAC	FERSIL		http://www.fersil-railway.com/php/systeme-cacolac-en.php
Platform screen door	FERSIL	France	
DOF1 (system to open and close platform screen door)		France	http://www.dof1.eu/index_en.php
COPP (control system to open and close platform screen door)		France	http://www.copp.fr/php/presentation-en.php

3.2.1 Platform edge extender

Movable platforms are suitable for reducing gaps in stations located on curved tracks (Federal Railroad Administration (FRA) 2007). This technique has been implemented in New York City subways, and train stations in Hong Kong (Figures 20, 21 and 22). The moveable platforms are metal platforms that move from the end of the station platform to the side of the train car when the train is stationary.

Figure 20: Platform edge extender at 14th Street, New York

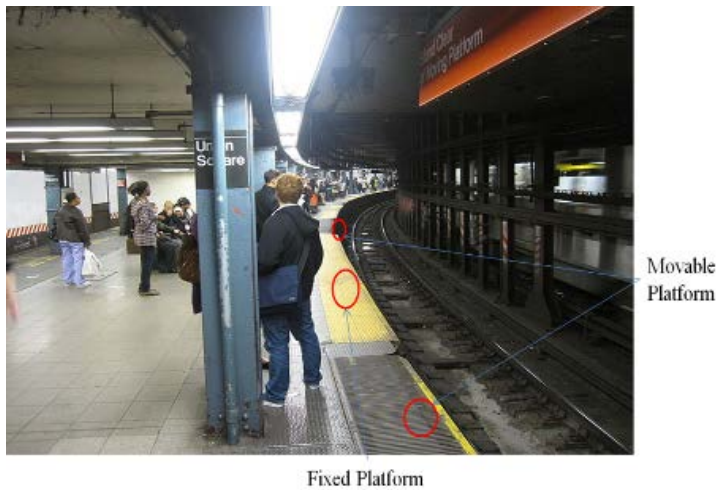

(Image courtesy: http://en.wikipedia.org/wiki/Platform_gap_filler)

Figure 21: Platform gap filler in Hong Kong



(Image courtesy: http://en.wikipedia.org/wiki/Platform_gap_filler)

Figure 22: Platform edge extender at South Ferry, USA



(Image courtesy: http://en.wikipedia.org/wiki/Platform_gap_filler)

3.2.2 Movable platform edge

Fold-up edges are also in use that provide comfortable boarding for commuter trains, but can be folded out of the way to allow wide freight trains and other wide vehicles to pass (FRA 2007). The movable platform edge is connected to the platform by a hinge support. As it requires the train to stop before actuation, it delays the train.

Figure 23: Movable platform edge

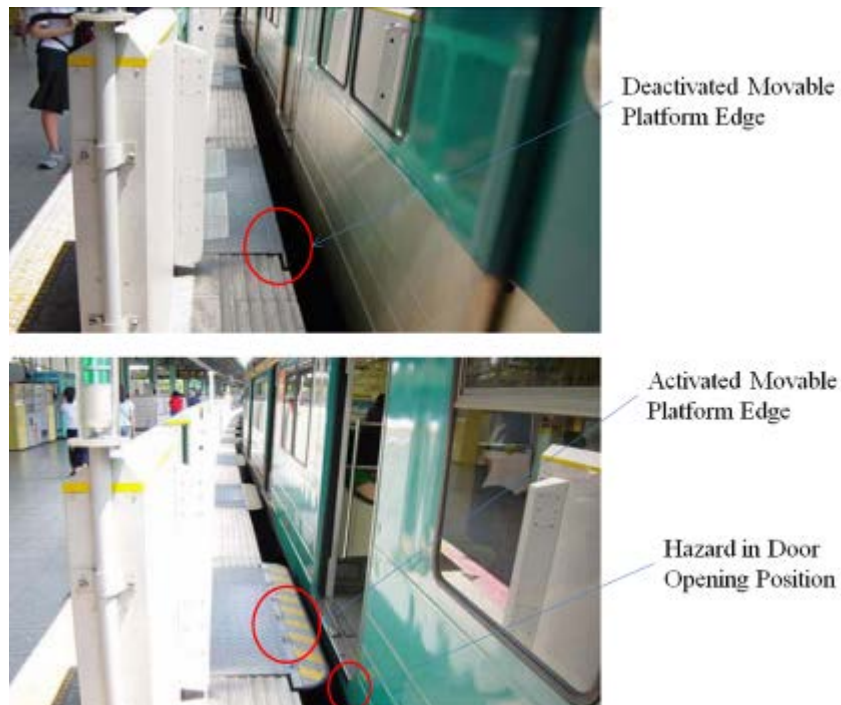

(Source: FRA 2007)

3.2.3 Automatic gap filler

The 2.5 m long gap filler, with a gap filling range of 40 cm, has been automated based on the measurement of the gap and the arrival of trains. This method is under experiment in France. The gap filler runs with the controller system known as CACOLAC. The three-part gap filler ensures variable gap filling along the length of the platform, which can be useful in providing access on both curved and straight platforms and tracks.

Figure 24: Automatic gap filler

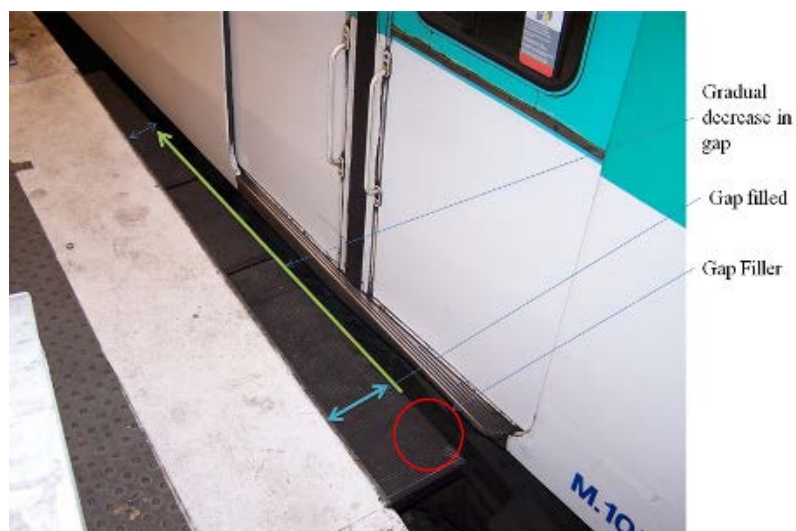

3.2.4 Extended rubber finger

A rubber platform edge with fingers that extend towards the door threshold has been developed and is commercially available. It is in use in South Korea. The main problem with this method is it can be bent out of the way if struck by a passing train (FRA 2007). Modification of this design has been proposed in a patent (Lee 2008), as discussed in section 3.1.9.

Figure 25: Extended rubber fingers

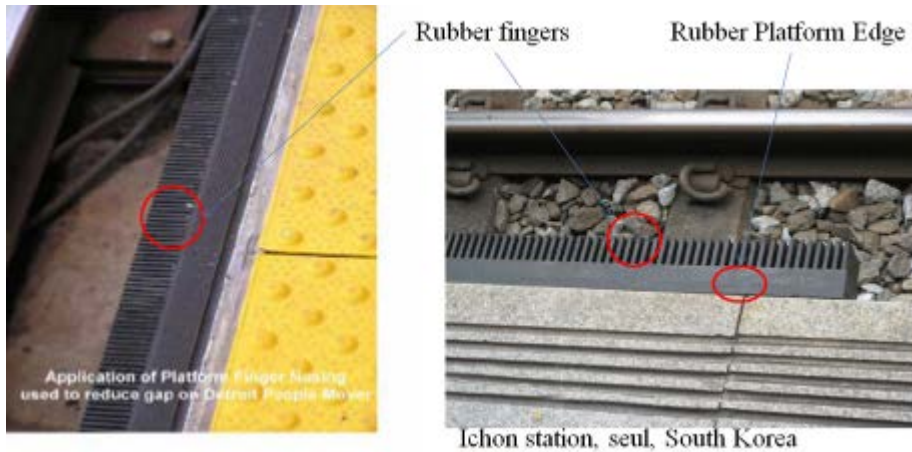

(Source: FRA 2007)

3.2.5 Rubberised on-board gap filler

A rubberised gap filler can be added to the threshold plate of trains to minimise the gap. However, it is not suitable for large gaps on curved tracks, as the train also has to pass through narrower gaps at stations located on straight tracks.

Figure 26: Rubberised gap filler added to a train

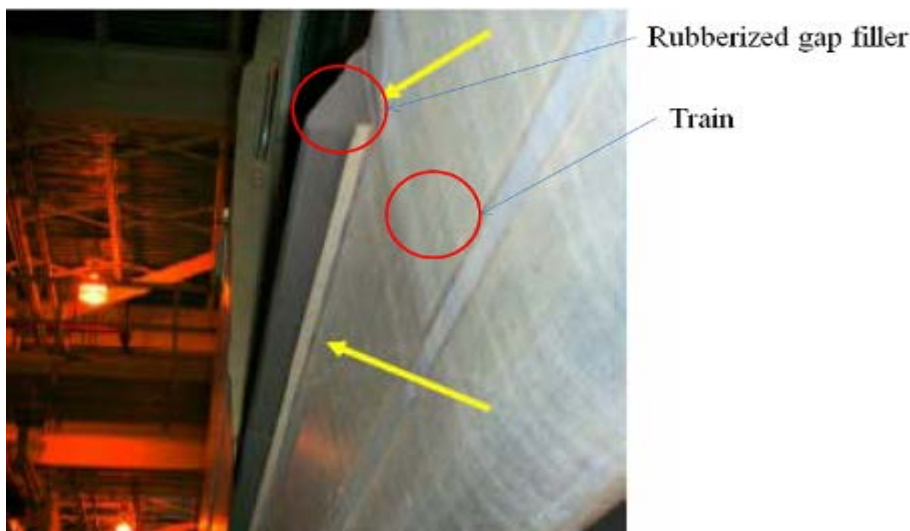

3.2.6 Power bridge plate

Power bridge plates extend the door threshold towards the platform edge and bridge the gap completely (FRA 2007).

3.2.7 Westinghouse platform screen door gap filler

The commercially available Westinghouse platform screen door gap filler automatically extends from platform side through an electrical drive system when a train reaches a station. The time required for extension and retraction is one second each way. The moving unit is divided into three sections in order to facilitate maintenance and replacement of the gap filler. The gap filler can reach up to a gap of 200 mm (Westinghouse 2010). An in-built control system ensures safety of operation by interlocking the device during train movement. It is also possible to control it by instruction if the system is not working properly. Manual retraction has been facilitated by using a hand crank in case of emergency.

Figure 27: Westinghouse platform screen door gap filler

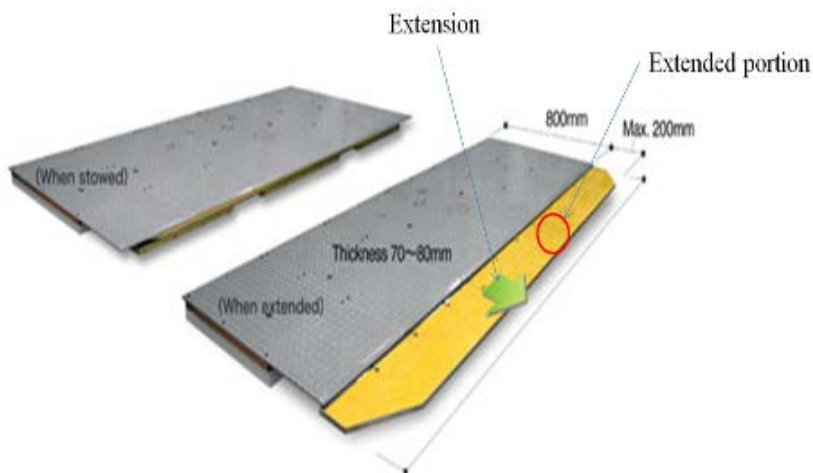

3.2.8 Matangi on-board ramp

Kiwi Rail showcased the Matangi passenger trains at CORE 2010. They use a manual on-board ramp for bridging the train-to-platform gap. Figure 28 shows the on-board ramp in executed position on the platform. This solution requires manual assistance for deploying the ramp.

Figure 28: Matangi manually deployed on-board ramp



3.2.9 Glidelok ramp

Kevin Fullerton, an architect from Brisbane, submitted the Glidelok ramp for Fresh Innovators 2005. The ramp, shown in Figure 29, retracts into a compact cassette only 11 cm high and 16 cm deep, and can easily be bolted under the train's doorstep. The multi-plate system assembles itself inside the cassette as it extends, and finds the platform level, so there are no moving parts exposed. Built-in sensors can detect if the ramp is obstructed, and stop it.

Figure 29: Glidelok ramp



(Image courtesy: <http://www.scienceinpublic.com/freshinnovators/2005/Kevin/kevinfullerton.htm>)

3.2.10 Interchangeable step design

This solution, proposed by Morlok (2001), helps to solve the bridging of vertical and horizontal gaps on both high and low level platforms. The stairway and trap can be rotated about the axis A–A to provide access for different platform types. A sliding lower step can be extended at lower level platforms to eliminate the first step gap problem.

Figure 30: Interchangeable step design

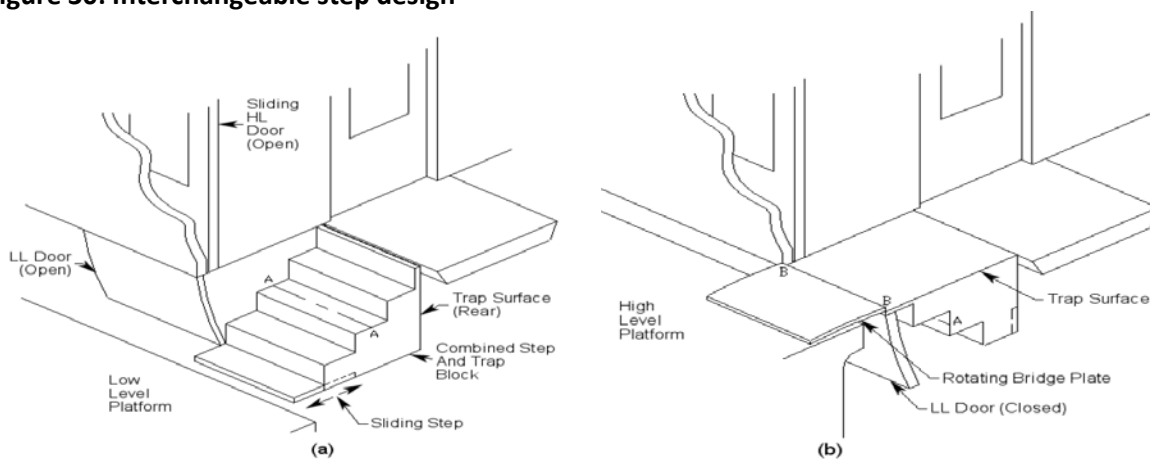

(a) at low level platform

(b) at high level platform

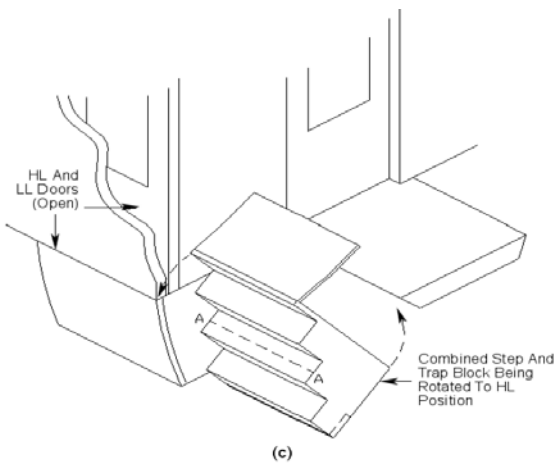

(c) transitional from low to high between stations
(Source: Morlok 2001)

3.2.11 Corrugated platform edge

This solution is being used by a bus station in Cali, Colombia (Rickert 2010). It uses a corrugated platform edge made of a wavy material to bridge the horizontal gap.

Figure 31: Corrugated platform edge



(Source: Rickert 2010)

3.3 Supporting devices for platform gap fillers

In order to be operationally effective, some platform gap fillers need to have supporting devices that activate them in the right time at the right place and ensure safety of passengers.

3.3.1 CACOLAC (ClearSy 2007)

The control system CACOLAC helps the automatic gap filler controller device to fold and unfold, based on the observation of the behaviour of each train through sensors located on each platform. The sensor system uses two distance indicators (laser and hyper frequency), three presence sensing devices (triangular infrared), and two speed radars (with the Doppler effect) to determine the arrival of a train, stopping of a train at the platform, the zones of train stopping, and the departure of a train from a station. The control system manipulates the required command to the gap filler mechanism, based on sensor information. The system takes care of safety against failure by adding redundant sensors in the system. A company namely Bigorre Ingenierie (ClearSy 2007) has designed the gap filler system with CACOLAC.

Figure 32: CACOLAC system

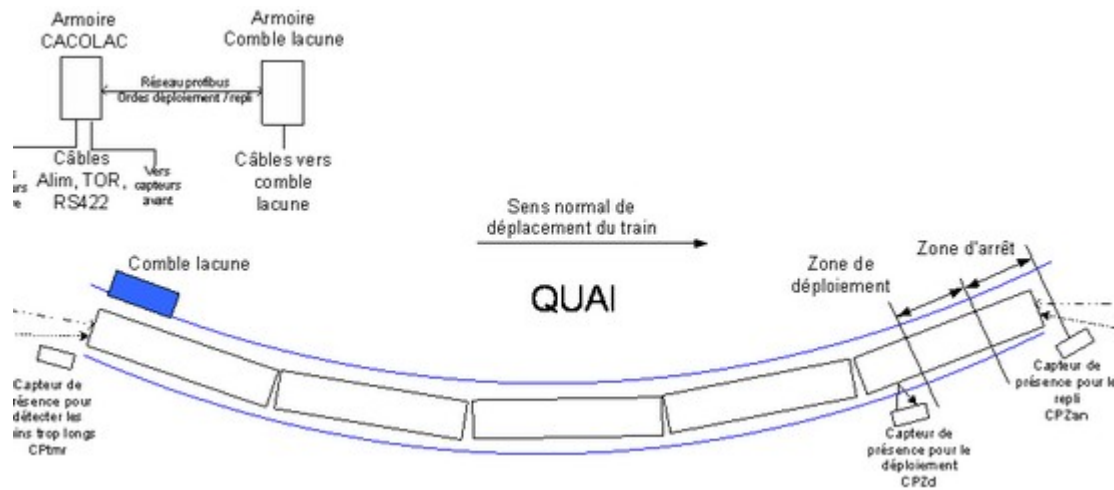

3.3.2 Platform screen doors

Platform screen doors have been used in France to prevent passengers entering or falling onto tracks (Lecomte et al. 2010). This accessory does not fill the gap between train and platform, but it can reduce the risk of injury during actuation of any gap-filling device in use.

Figure 33: Platform screen door



3.3.3 Devices to open and close platform screen doors

Platform screen doors installed on any platform need to open when a train reaches the station and the train door is open. ClearSy developed COPPILOT, DOF1 and COPP (Lecomte et al. 2010) to automate the opening and closing of platform screen doors. All three controllers have been installed in different railway stations to check the integrity levels of safety at different stages of operations.

The COPP uses sensors to observe an area of track to detect the behaviour of trains and open the platform screen doors as required (ClearSy 2010). The COPP system has been designed to serve for one platform only. DOF1 is capable of preventing train doors on the opposite side of the platform from opening (Lecomte et al. 2010).

3.4 Proposed new solutions

This section will discuss possible new solutions and the technologies related to them. A solution for bridging the gap between the platform and train should address the issues of:

1. horizontal gap (low level platforms)
2. vertical gap (low level platforms)
3. horizontal gap (high level platforms)
4. vertical gap (high level platforms).

Most of the solutions discussed in sections 3.1 and 3.2 cater only for one or two of these issues, apart from the Glidelok ramp and the interchangeable step design proposed by Morlok (2001). There is a need to combine one or more solutions to address all four issues. The solutions listed in these sections can be considered for future analysis.

3.4.1 Movable platform steps

The movable platform steps concept uses both vertical and horizontal moving blocks of steps to address all four gap issues. It can cater for both high and low level platforms. The working principle of the concept is shown in Figure 34. Both steps extend vertically outward, based on the vertical distance requirements. Then step 2 moves horizontally towards the train door to cover up the horizontal gap. The extent of movement both horizontally and vertically can be controlled, based on the required gap. Steps are much more comfortable for able-bodied passengers to access than a ramp, and vice versa for disabled people. This solution requires permanent platform modification.

Figure 34: Illustration of movable platform steps

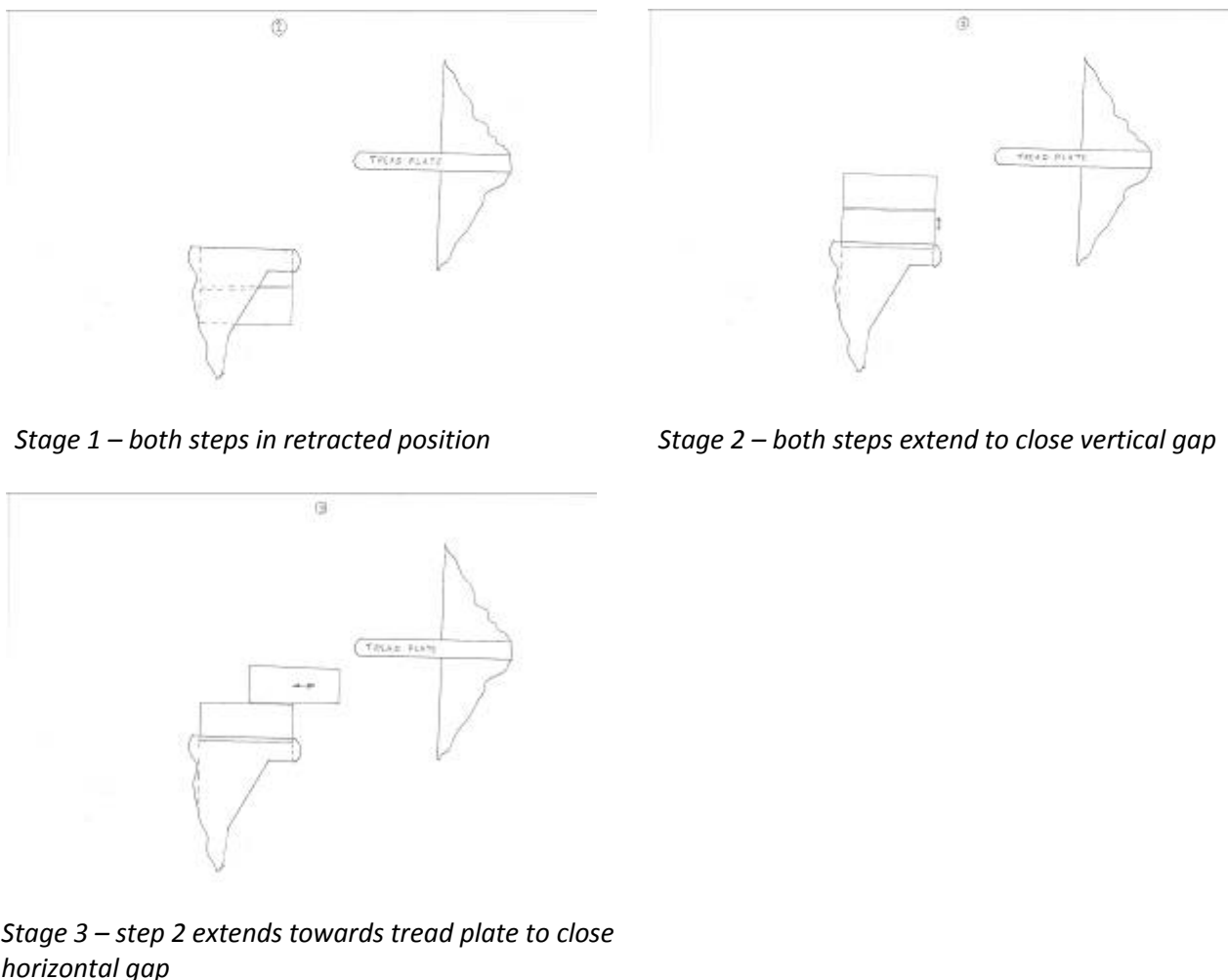

3.4.2 Movable platform ramp

The movable platform ramp concept also uses both vertical and horizontal movements to address all four gap issues. It can also cater for both high and low level platforms. A working principle of the concept is shown in Figure 35:

1. **Stage 1:** Ramp block, which has a hinged ramp, is in a stationary position as the train comes to a halt.
2. **Stage 2:** The ramp block extends horizontally to close the horizontal gap. The ramp block is actuated by a hydraulic cylinder.
3. **Stage 3:** The ramp slides vertically to close the vertical gap, also actuated by a hydraulic unit.

Figure 35: Illustration of movable platform ramp

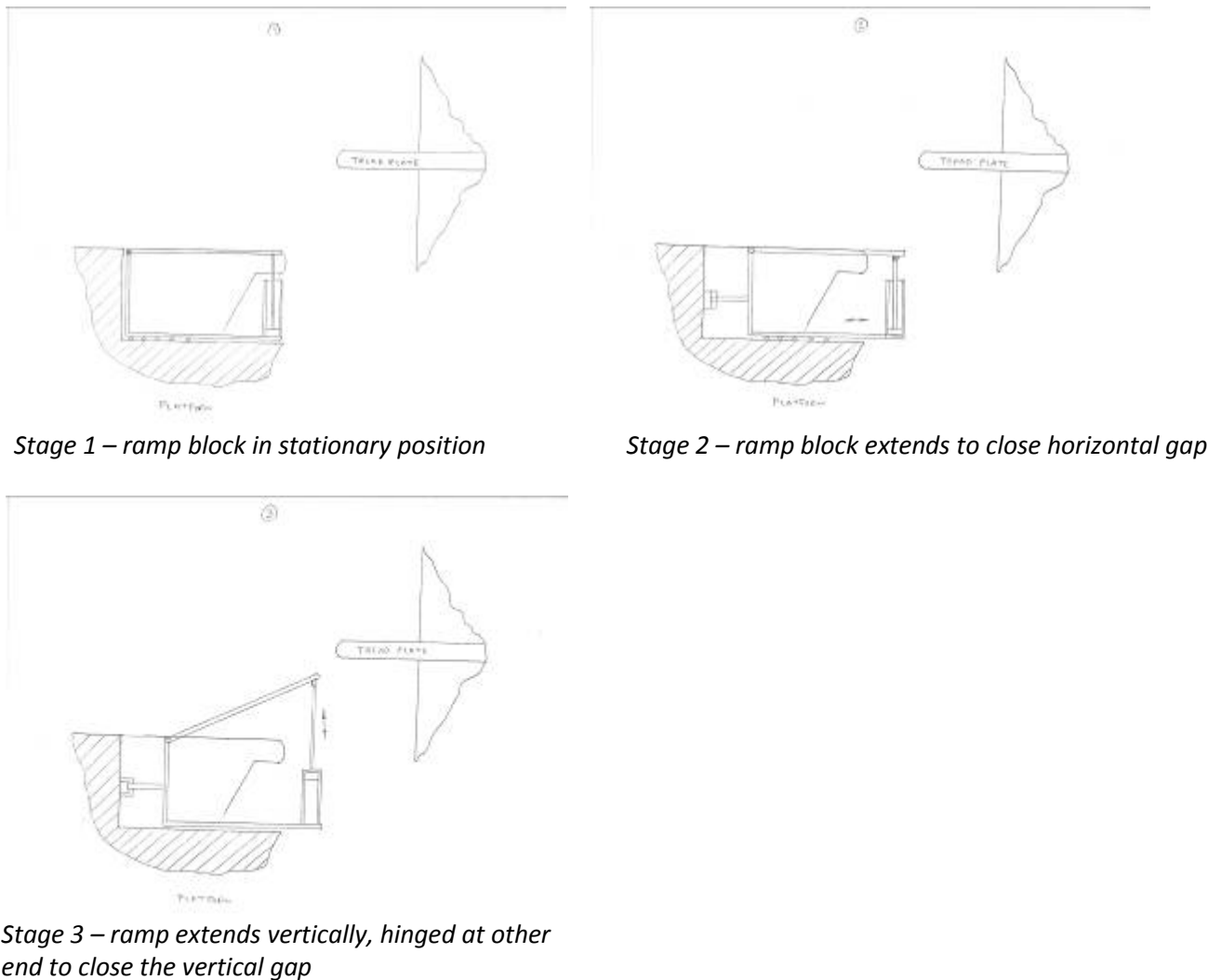

3.4.3 Movable on-board steps

The movable train steps also use two kinds of movements to address all four issues. It uses two vertically moving step configurations (stage 2 and stage 3), as shown in Figure 36 to close the vertical gap, while the horizontal gap is closed by a final horizontal movement of the tread plate (stage 4). It is an on-board solution, so it can cater for both high and low level platforms. On arriving at the station, the distance required to bridge the gap can be evaluated by the sensor system, and the movement of the plates thus controlled.

Figure 36: Illustration of movable on-board steps

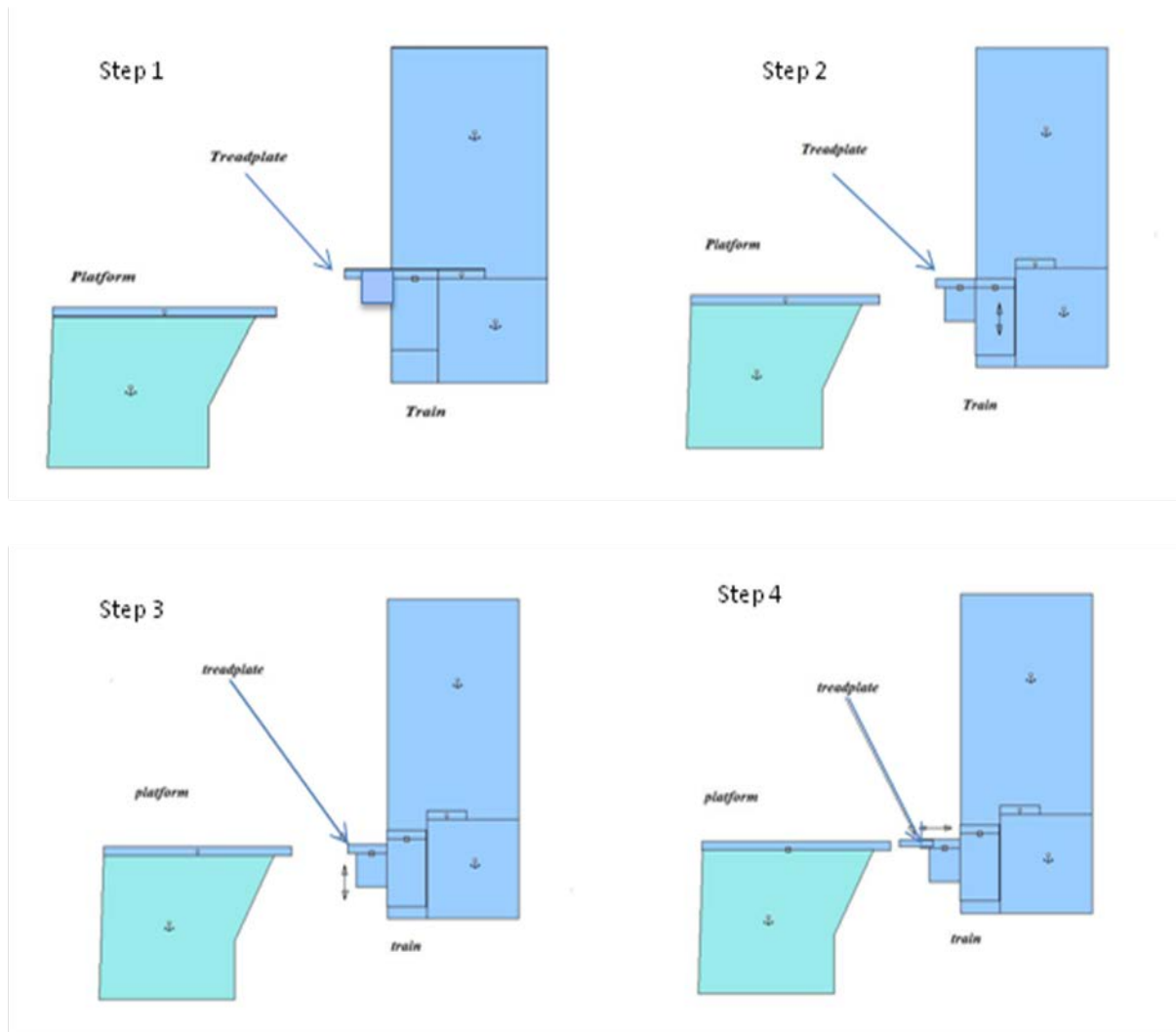

Stage 1 – train at rest.

Stage 2 – first set of steps acts as a block and lowers to the required distance.

Stage 3 – second set of steps independently lowers to close vertical gap.

Stage 4 – tread plate moves horizontally towards the platform to close horizontal gap.

3.4.4 Hinged on-board ramp

The hinged on-board ramp is similar to the movable on-board steps in that it can be used to address all gap issues and cater to both high and low level platforms. Slots are cut on the platform to accommodate the location bars for a stable ramp that doesn't move. A series of hinged plates extends from the tread plate by guides, and keeps extending and swinging until it reaches the slotted electromagnetic platform. The extending and swinging stops under overload due to the magnetic attraction between the tread plate locating bars and platform slots. Figure 37 shows the illustration of the hinged on-board ramp.

Figure 37: Illustration of hinged on-board ramp

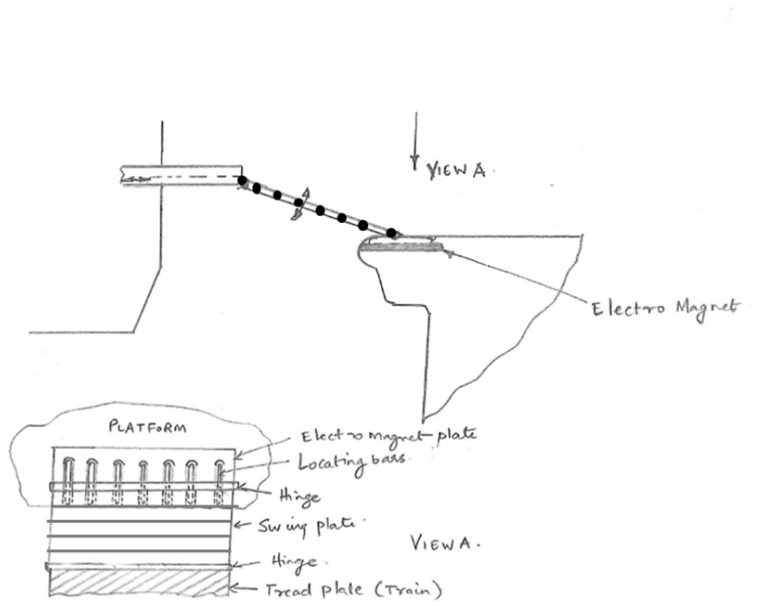

3.4.5 Smaller wheels

The option of using smaller diameter wheels can be explored. This can reduce the vertical gap between the tread plate and the platform. It must be combined with a horizontal gap-closing solution to get the desired result. Exploration of smaller wheels has been recommended by the Significant Steps research (Atkins Rail 2004). Smaller wheels with harder material can adjust to the wear resulting from more revolutions to cover the same distance as larger wheels.

3.4.6 Use of parallel tracks

The use of two tracks — one for trains not stopping at the stations and one for trains stopping at the stations — can reduce the horizontal gap as the new track need not consider clearance for freight or moving trains. A switch can be used just before the station to guide the train onto the right track. This switch may not be a standard switch, as both rails will be very close. A new kind of switch design has to be explored for this particular application. Figure 38 illustrates the use of parallel tracks.

Figure 38: Illustration of use of parallel tracks

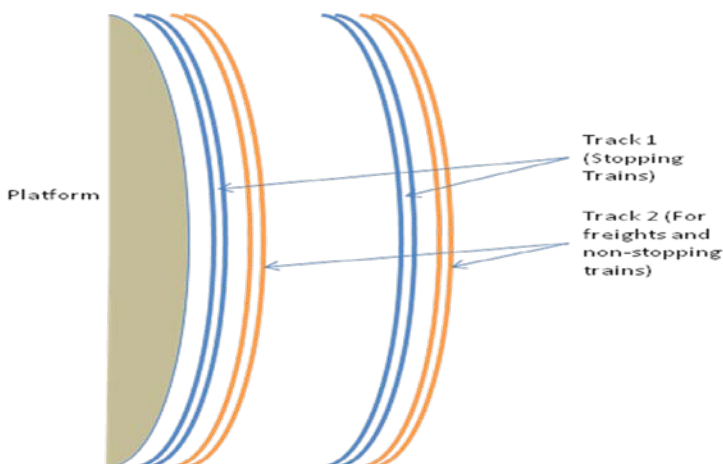

3.5 Gap mitigation by existing solutions

The horizontal and vertical gaps between the platform and train interface are influenced by various factors, as discussed in section 2.3. Sections 3.1, 3.2 and 3.3 discuss various solutions and technologies (patented or used worldwide) to address the platform-to-train gap issues. These solutions are generally designed and developed to mitigate the gap between the platform and train. But some of the solutions are designed for a specific purpose (closing the horizontal gap only), and do not completely meet the demand of mitigating both horizontal and vertical gaps. Most of the solutions described in this report are designed to cater for the horizontal gap at a high level platform. The horizontal gap is considered to be a more critical safety issue than the vertical gap due to the increasing number of injuries to passengers falling into the gap. The solutions described in the report are either platform-based or rolling stock-based, as shown in Figure 39.

3.5.1 Platform-based solutions

Platform-based solutions range from major platform modification to just screwing a device onto the platform. Platform-based solutions need to take into consideration different types of rolling stock operating on that platform. Platform-based solutions can be further divided into fixed or movable.

Fixed solutions (see Figure 39) are mostly flexible rubber block or extensions used to partially or completely close the horizontal gap. This kind of solution can be used both for straight and curved platforms.

The advantages to fixed solutions are:

- no delay in train operations
- cheaper installation and maintenance
- no major platform modification required.

The limitations of fixed solutions are:

- the need to know the different types of rolling stock that operate on the platform and the horizontal and vertical gaps prior to installation
- limited ability to reduce the vertical gap
- more wear and tear due to physical contact with the train.

Movable solutions (see Figure 39) use sensors to sense the position of the train door step in relation to the platform, and deploy their device to the desired position. Like fixed platform solutions, movable solutions don't cater for vertical gaps.

The advantages to movable solutions are:

- sensors used to sense the train-to-platform gap can accommodate any variation.

The limitations of movable solutions are:

- delays in train operations, as the sensing elements mostly work after the trains stop
- expensive installation and maintenance
- major platform modification required.

3.5.2 Rolling stock-based solutions

Rolling stock-based solutions use manually operated, fixed or movable devices to close the vertical and horizontal gaps. Some rolling stock-based solutions cater for both horizontal and vertical gaps. Most of the rolling stock-based solutions are designed for high level platforms, apart from the interchangeable step design (3.2.10). Rolling stock-based solutions can be divided into fixed or movable solutions.

The fixed solution shown in Figure 39 is a rubber block fixed to the tread plate to reduce the horizontal gap. It cannot be used on the curved platforms, and does not cater for vertical gaps.

The advantages to the fixed solution are:

- no delay in train operations
- cheaper installation and maintenance
- no major modification required.

The limitations of the fixed solution are:

- cannot be used on curved tracks as the gaps are larger
- inability to close the vertical gap
- more wear and tear due to physical contact with the train.

Movable solutions (see Figure 39) use sensors to sense the position of the train door step in relation to the platform, and deploy the device to the desired position. Manually operated ramps like the Matangi on-board ramp (3.2.8) are deployed after the train comes to a halt. Rolling stock-based movable solutions like the train-to-platform gap mitigator (3.1.2), interchangeable step design (3.2.10) and Glidelok ramp (3.2.9) cater for vertical and horizontal gaps.

The advantages to movable solutions are:

- cater for both horizontal and vertical gaps.

The limitations of movable solutions are:

- delays in train operations
- expensive installation, operation and maintenance.

Figure 39: Solutions to mitigate the train-to-platform gap

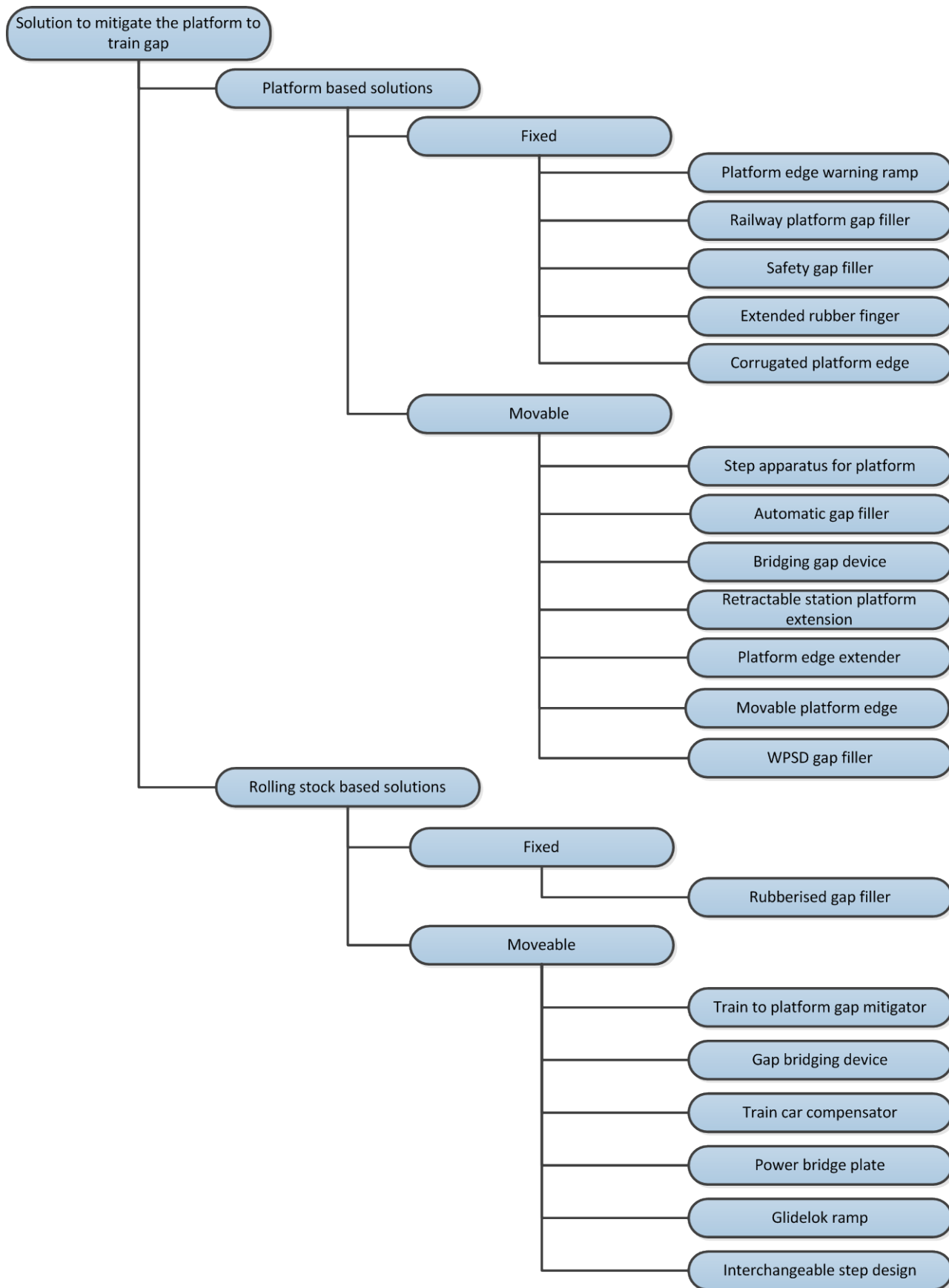

4. Qualitative assessment of solutions

Once potential gap-closing solutions are identified, the optimal solution that meets all specifications has to be recognised. A set of decisive factors that support the solution selection are required. A performance value for each solution with respect to these decisive factors must be estimated for ranking them. This performance assessment can be performed in two ways:

- quantitative analysis — needs actual data about solutions’ features and functions
- qualitative analysis — does not need actual data, but subject to variation.

Since there is no publicly available quantitative information about the solutions or the actual platform gap issues in Australia, a basic qualitative analysis was performed in the current research project. Qualitative analysis can be defined as a subjective judgment based on non-quantifiable information. It is essential to select the suitable option from different gap-closing solutions. It has been identified that related cost, implementation time and constraint, ease of operation, applicability in various conditions, and degree of success in minimising gaps are important parameters for any gap-closing solution (Figure 40).

Figure 40: Parameters identified for qualitative assessment

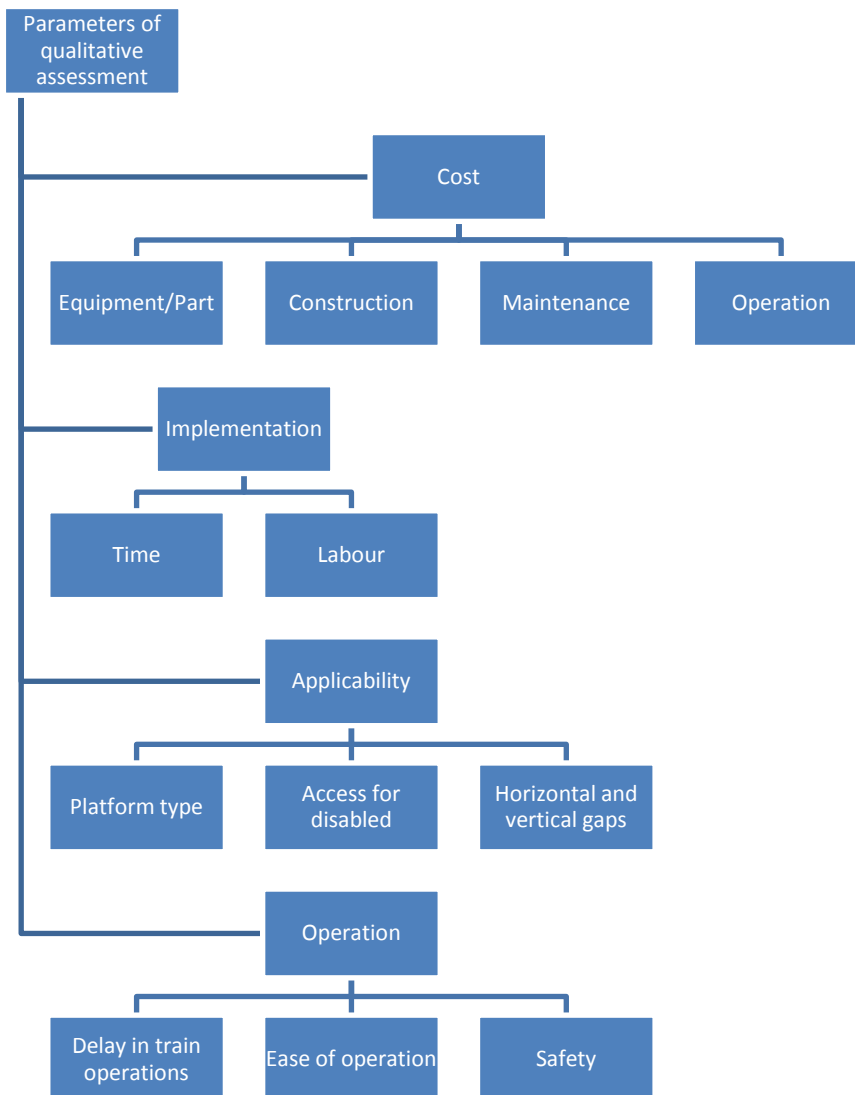

4.1 Parameters for qualitative assessment

Table 2 (see p. 38) shows the rating values for all parameters.

4.1.1 Cost

Cost is an important parameter in selecting an optimum solution. Different cost aspects influencing the solutions are discussed below:

- **equipment/parts** — it is assumed that if the equipment or parts are stationary and directly fixed to the platform, then the cost would be less than an electronic actuator or a control system
- **construction** — from a construction standpoint, the option with the least modification to the existing setup would have the lowest cost
- **maintenance** — preventive or scheduled maintenance at regular intervals is assumed to be less expensive than failure or replacements
- **operation** — using actuators or electronic equipment and control devices is considered to be expensive compared to stationary devices and mechanical setups.

High cost is undesirable, and hence a solution's overall rating reduces with the increase in costs.

4.1.2 Implementation

The time required to implement a technology at a station is an important issue for the evaluation of the solutions. Understanding the construction, a subjective weighting has been used. Low implementation time is regarded as most suitable, so a 'high' rating applies to technology that requires less time to implement.

Labour needed for effective implementation of the technology has also been considered as an important factor, as it can have an effect on the time required to implement the technology. Implementation of highly technical equipment requires highly trained specialists.

4.1.3 Applicability

Applicability as a parameter refers to a number of issues:

- **platform types** — it is obvious that not all solutions are suitable for all platforms. A solution which closes the platform gap for a straight track might not work on a curved platform with a tighter radius. Solutions that can be used in various conditions have been rated as 'high' in the rating system
- **access for disabled** — the gap-closing solutions can be ranked based on how they provide access for disabled people. A high rating is given if a solution allows for independent access for the disabled (and satisfies DSPAT requirements)
- **horizontal and vertical gaps** — it is desirable that both the horizontal and vertical gaps between the train and platform would be minimised by application of a gap-closing solution, although not all solutions fill both gaps. Given that minimising horizontal gaps can reduce fatalities significantly, and considering the complexity in installing a solution to minimise both horizontal and vertical gaps, it has been considered adequate to minimise the horizontal gap only in many cases. Although a high rating has been proposed for those successful in minimising both horizontal and vertical gaps for all people, solutions that minimise the horizontal gap, where minimising both horizontal and vertical gaps is not achievable, are also acceptable.

4.1.4 Operations

Solutions were also ranked based on factors like delay in train operations, ease of operation and safety to passengers:

- **delay in train operations** — if a solution is fixed and does not need any external influence to operate, then there will be no interruptions to the train timings. Some of the gap-closing solutions require actuators to put them into operation. Therefore, if the device operates after the train has stopped, there will be delay due to deployment and retrieval

- **ease of operation** — complexity in operating actuators can lead to delays in train operations. In the present rating system, a high value is proposed for solutions that are easy to operate and fast to execute
- **safety** — safety is another important aspect that needs to be considered during operation. Gap-closing solutions with moving parts need to have provisions to ensure the safety of passengers during their actuation. A high rating is also given to a solution that provides independent access to the disabled.

4.2 Weighting of criteria

Solutions were rated based on the factors discussed above, and given a weighting as shown in Table 1. Each factor was given a maximum 10 point rating, and the solutions were rated based on their subjective performance. The three factors of the applicability parameter were given a higher weighting (40%, compared to 20% for the other parameters), as these factors were considered more important. The overall rating for the different factors were manipulated based on the rating. If a factor had a low rating, then the rating for that factor was subtracted by 10 to get the desired points. For example, the lower the equipment cost the lower will be the score on the factor table as seen in Table 2, but it will have a negative effect on the overall scoring. So the scoring is balanced by subtracting the actual value by 10.

4.3 Ranking of all solutions

All the solutions were rated based on the subjective information from the literature, and on assumptions. The solutions are rated overall against a score of 100. The solutions are also ranked separately for four different parameters. The ranking results are attached as Appendices 1–5. As pointed out earlier, the weighting can be changed as required, but the ranking would change as the weighting is changed. This ranking highlights solutions that address gap issues of straight and curved platforms, horizontal and vertical gaps, and independent access by passengers with special needs. The qualitative assessment is shown in Table 3. Although the qualitative assessment was carried out for the proposed new solutions, they were not considered for the ranking.

4.4 Discussion

This section of the report will discuss in detail the top five ranked solutions for each parameter, and the overall ranking.

4.4.1 Ranking based on cost

1. Corrugated platform edge (3.2.11):
 - plug and play system
 - fixed system
 - no platform modification required
 - no external systems required
 - no operation costs
 - low replacement cost
2. Safety gap filler (3.1.9) and platform gap filler (3.1.4):
 - plug and play system
 - fixed system
 - no platform modification required
 - no external systems required
 - no operation costs
 - low replacement cost
3. Glidelok ramp (3.2.9):
 - plug and play system

- on-board system
 - no rolling stock modification required
 - operation costs exist
4. Matangi on-board ramp (3.2.8):
 - on-board system
 - rolling stock modification required
 - no external systems required
 - manual operation costs exist
 - low replacement cost

4.4.2 Ranking based on implementation

1. Corrugated platform edge (3.2.11):
 - plug and play system
 - fixed system
 - no platform modification required
 - no special training required
 - less implementation time
2. Safety gap filler (3.1.9) and platform gap filler (3.1.4):
 - plug and play system
 - fixed system
 - no platform modification required
 - no special training required
 - less implementation time
3. Rubberised on-board gap filler (3.2.5):
 - plug and play system
 - fixed on-board system
 - no rolling stock modification required
 - no special training required
 - less implementation time
4. Platform gap filler (3.1.4):
 - plug and play system
 - fixed system
 - no platform modification required
 - longer implementation time due to gap measurements

4.4.3 Ranking based on applicability

1. Glidelok ramp (3.2.9):
 - suitable for both straight and curved platforms
 - independent access for disabled people
 - caters for both horizontal and vertical gaps
2. Matangi on-board ramp (3.2.8):
 - suitable for both straight and curved platforms
 - independent access for disabled people
 - caters for both horizontal and vertical gaps

3. Train-to-platform gap mitigator (3.1.2):
 - suitable for both straight and curved platforms
 - independent access for disabled people
 - caters for both horizontal and vertical gaps
4. Interchangeable step design (3.2.10):
 - suitable for both straight and curved platforms
 - independent access for disabled people
 - caters for both horizontal and vertical gaps
5. Step apparatus for platform (3.1.3):
 - suitable for both straight and curved platforms
 - dependent access for disabled people
 - caters for both horizontal and vertical gaps

4.4.4 Ranking based on operations

1. Platform edge warning ramp (3.1.1):
 - fixed, so no delay in trains
 - no manual operation required
 - does not completely close the horizontal and vertical gaps
2. Corrugated platform edge (3.2.11):
 - fixed, so no delay in trains
 - no manual operation required
 - does not completely close the vertical gap
3. Rubberised on-board gap filler (3.2.5):
 - fixed, so no delay in trains
 - no manual operation required
 - does not close the vertical gap
4. Safety gap filler (3.1.9) and platform gap filler (3.1.4):
 - fixed, so no delay in trains
 - no manual operation required
 - does not close the vertical gap
5. Glidelok ramp (3.2.9):
 - delay in train operations due to operation
 - automatic, but human intervention required
 - safer because it closes both horizontal and vertical gaps

4.4.5 Overall ranking

1. Glidelok ramp (3.2.9):
 - plug and play system
 - no rolling stock modification required
 - suitable for both straight and curved platforms
 - independent access for disabled people
 - caters for both horizontal and vertical gaps

2. Safety gap filler (3.1.9):
 - plug and play system
 - fixed system
 - no platform modification required
 - no delay in train operations
 - low implementation time
 - caters only for horizontal gap
 - low maintenance and operation costs

3. Matangi on-board ramp (3.2.8):
 - suitable for both straight and curved platforms
 - independent access for disabled people
 - caters for both horizontal and vertical gaps
 - manually operated
 - low maintenance and operation costs

4. Interchangeable step design (3.2.10):
 - suitable for both straight and curved platforms
 - independent access for disabled people
 - caters for both horizontal and vertical gaps

5. Platform gap filler (3.1.4):
 - plug and play system
 - fixed system
 - no platform modification required
 - no delay in train operations
 - caters only for horizontal gap
 - low maintenance and operation costs

Table 2: Rating of different parameters for qualitative assessment

Parameters		Value	Rating	Action	Points	Weighting
Cost	Equipment/part	High	Low	Stationary material, fixed to the platform	1 to 4	20
				Stationary material fixed on board	5 to 6	
				Actuator, movable platform	7 to 9	
				Control system (automatic)	10	
	Construction (labour and material)	High	Low	Modification of platform required	10	
				Modification of rolling stock required	4 to 6	
				Plug and play	1 to 3	

Parameters		Value	Rating	Action	Points	Weighting
	Maintenance during operation	High	Low	Scheduled	4 to 6	
				Failure	7 to 9	
	Operation	High	Low	Additional labour	1 to 3	
				Actuator fuel, electricity etc.	4 to 6	
Both labour and fuel				7 to 10		
Implementation	Time	High	Low	1–7 days	1 to 3	20
				2–3 weeks	4 to 6	
				1 month	7 to 9	
				>3 months	10	
	Labour	High	Low	Unskilled labour	1 to 3	
				Training required	4 to 9	
Only by manufacturer				10		
Applicability	Supports different platform types	High	High	Straight only	5	40
				Both straight and curved	10	
	Access for disabled	High	High	Easy access (independent)	10	
				Normal access with manual help	5	
				Difficult access	0	
	Minimising both vertical and horizontal gap	High	High	Horizontal only	5	
Horizontal and vertical				10		
Operation	Delay in train operations (This is more of a probability factor)	High	Low	Fixed	0	20
				before train approaches	1 to 3	
				Simultaneous operation	4 to 6	
				After a train reaches	7 to 9	
	Ease in operation	High	High	Manually operated	1 to 3	
				Semi-automatic	4 to 6	
				Automatic	7 to 10	
	Safety	High	High	Disabled with person assistance	4 to 6	
				Independent disabled access (slip resistance, tactile indicators, hand rails, signage)	7 to 10	

Table 3: Qualitative assessment

	Cost						Implementation				Applicability				Operation				Overall rating		
	Equip	Const	Maint.	Op	Total		Time	Labour	Total		Platform	Access	Vertical.	Total		Delay	Ease.	Safety	Total		/100
	/10	/10	/10	/10	Actual	Converted	/10	/10	Actual	Converted	/10	/10	/10	Actual	Converted	/10	/10	/10	Actual	Converted	
Patents																					
Platform edge warning ramp (Hanrahan, Keegan & Goffe 1995)	5	7	4	4	20.0	10.0	6	7	7.0	7.0	5	10	5	20.0	26.7	0	5	9	24.0	16.0	59.7
Train-to-platform gap mitigator (Chisena 2008)	10	10	5	5	10.0	5.0	7	10	3.0	3.0	10	10	10	30.0	40.0	9	8	8	17.0	11.3	59.3
Step apparatus for platform (Yamaguchi et al. 2001)	5	3	6	5	21.0	10.5	3	7	10.0	10.0	10	5	10	25.0	33.3	9	8	4	13.0	8.7	62.5
Railway platform gap filler (Muller 1998)	4	3	8	3	22.0	11.0	3	3	14.0	14.0	10	5	5	20.0	26.7	6	8	5	17.0	11.3	63.0
Gap-bridging device for train platforms (Winkelmann & Hug 2010)	7	1	5	6	21.0	10.5	2	7	11.0	11.0	10	0	5	15.0	20.0	9	8	4	13.0	8.7	50.2
Automatic gap filler (Vincent-Genod 2003)	4	5	8	5	18.0	9.0	3	6	11.0	11.0	10	5	5	20.0	26.7	6	8	5	17.0	11.3	58.0
Train car compensator (Drago 2008)	7	3	5	5	20.0	10.0	3	8	9.0	9.0	5	0	5	10.0	13.3	9	7	5	13.0	8.7	41.0
Gap-bridging device (Lomberty et al. 2010)	9	10	6	6	9.0	4.5	7	10	3.0	3.0	10	5	5	20.0	26.7	9	8	5	14.0	9.3	43.5
Safety gap filler (Lee 2008)	1	1	7	1	30.0	15.0	1	1	18.0	18.0	5	5	5	15.0	20.0	0	7	5	22.0	14.7	67.7
Retractable station platform extension (Klohn 1996)	7	6	5	5	17.0	8.5	4.0	5.0	11.0	11.0	5	0	5	10.0	13.3	3	7	5	19.0	12.7	45.5

	Cost						Implementation				Applicability				Operation				Overall rating		
	Equip	Const	Maint.	Op	Total		Time	Labour	Total		Platform	Access	Vertical.	Total		Delay	Ease.	Safety	Total		/100
	/10	/10	/10	/10	Actual	Converted	/10	/10	Actual	Converted	/10	/10	/10	Actual	Converted	/10	/10	/10	Actual	Converted	
Solutions from around the world																					
Movable platform	7	10	5	5	13.0	6.5	9	9	2.0	2.0	10	5	5	20.0	26.7	7	9	5	17.0	11.3	46.5
Movable platform edge	4	10	5	5	16.0	8.0	6	7	7.0	7.0	10	5	5	20.0	26.7	7	9	5	17.0	11.3	53.0
Automatic gap filler	10	3	5	5	17.0	8.5	7	10	3.0	3.0	10	5	5	20.0	26.7	9	9	5	15.0	10.0	48.2
Platform gap filler	1	1	7	1	30.0	15.0	1	1	18.0	18.0	5	5	5	15.0	20.0	0	7	5	22.0	14.7	67.7
Rubberised on-board gap filler	5	2	7	3	23.0	11.5	2	2	16.0	16.0	5	0	5	10.0	13.3	0	9	5	24.0	16.0	56.8
WPSD gap filler	4	3	5	5	23.0	11.5	6	5	9.0	9.0	10	5	5	20.0	26.7	9	9	5	15.0	10.0	57.2
Matangi on-board ramp	6	5	2	2	25.0	12.5	5	4	11.0	11.0	10	10	10	30.0	40.0	9	0	5	6.0	4.0	67.5
Glidelok ramp	6	1	4	4	25.0	12.5	2	7	11.0	11.0	10	10	10	30.0	40.0	8	9	10	21.0	14.0	77.5
Interchangeable step design	8	3	5	6	18.0	9.0	8	10	2.0	2.0	10	10	10	30.0	40.0	8	8	9	19.0	12.7	63.7
Corrugated platform edge	1	1	7	1	30.0	15.0	1	1	18.0	18.0	5	0	5	10.0	13.3	0	9	5	24.0	16.0	62.3

	Cost						Implementation				Applicability				Operation				Overall rating		
	Equip	Const	Maint.	Op	Total		Time	Labour	Total		Platform	Access	Vertical.	Total		Delay	Ease.	Safety	Total		/100
	/10	/10	/10	/10	Actual	Converted	/10	/10	Actual	Converted	/10	/10	/10	Actual	Converted	/10	/10	/10	Actual	Converted	
New proposed solutions																					
Movable platform steps	8	10	7	5	10.0	5.0	7	8	5.0	5.0	10	0	10	20.0	26.7	7	9	6	18.0	12.0	48.7
Movable platform ramp	8	10	7	5	10.0	5.0	7	8	5.0	5.0	10	10	10	30.0	40.0	7	9	9	21.0	14.0	64.0
Movable on-board step	8	10	7	5	10.0	5.0	7	8	5.0	5.0	10	0	10	20.0	26.7	7	9	6	18.0	12.0	48.7
Hinged on-board ramp	6	6	7	5	16.0	8.0	5	8	7.0	7.0	10	10	10	30.0	40.0	7	8	9	20.0	13.3	68.3

5. Discussion and recommendations

The gap that exists between the platform and the train has been a major access issue in railways for a long time, particularly for disabled people. The DSPAT requirements for independent access by disabled people require the vertical gap to be less than 15 mm and the horizontal gap less than 40 mm. Existing platforms in Australia do not comply with these requirements. Currently, some passenger networks use manual ramps to assist access by disabled people. There are also low level platforms, with vertical gaps of 300 mm or more, making access for even able-bodied people difficult. Moreover, accidents due to the gap between the station platform and the train, particularly at curved platforms, make it a safety issue. To address these issues, there is a need for smarter solutions that provide safe independent access for disabled train passengers.

There are various factors that contribute to the train-to-platform gap. These factors have been discussed briefly in this report. There is limited scope for reducing the gap through modifying infrastructure. This constraint leads rail operators to look for an external solution to address the challenges. This report reviews various gap-closing solutions that are either patented or otherwise implemented around the world. Most of solutions reviewed provide mechanisms to close the horizontal gap, but they seldom cater for the vertical gap. Most of the solutions are also for high level platforms.

Considering the limitation in accessing quantitative information on the identified solutions, a qualitative assessment was conducted in order to rank them with respect to critical parameters. In this assessment, more weight was given to applicability than other criteria. The Glidelok ramp (Fullerton 2005) was ranked first based on its flexibility, ability to be retrofitted and applicability. In addition to existing solutions, some new solutions were also proposed, to be considered for review in future.

Overall, the project provided basic information and features of existing solutions, and qualitatively ranked them with respect to cost, time, implementation and maintenance. However, this small review project couldn't recommend any particular solutions or provide an implementation plan due to the time and resource constraints, and the project's limited scope. A detailed quantitative analysis, considering real-time costs, implementation time, applicability and operational aspects, is required to identify the optimal solutions for the Australian operational environment. In order to support this quantitative analysis, the following crucial questions have to be addressed.

1. How many passenger train stations are in Australia, and how can they be categorised with respect to the design characteristics of platforms and trains? This categorisation is essential, as there are variations in platform and train parameters across Australia. One solution is not adequate to achieve the required outcome for different types of platform, but different solutions can be used to achieve success under different conditions:
 - to address the horizontal and vertical gaps for a straight, high level platform
 - to address the horizontal and vertical gaps for a curved, high level platform
 - to address the horizontal and vertical gaps for a straight, low level platform
 - to address the horizontal and vertical gaps for a curved, low level platform.
2. What are the issues experienced by different types of train passengers in accessing train platforms?
3. What are the issues and constraints faced by passenger operators in closing the platform gap?
4. What factors, constraints and design parameters are to be considered to close the platform gap?
5. What are the existing gap-closing solutions, and are they adequate to address platform gap issues in Australia?
6. If the existing solutions are not feasible, do we need to develop new specific solutions through a design-based research project?
7. How do we analyse and validate the solutions and ensure that they are cost-effective, applicable and user-friendly?
8. What is the possible implementation plan for these solutions?

References

- Atkins Rail 2004, *Significant Steps research*, UK Department for Transport.
- Australian Bureau of Statistics 2003, *Disability, ageing and carers: Summary of findings*, 4430, Canberra.
- Bradshaw, J, *Mind the gap: A reference guide for people with disabilities riding trains – data report*, retrieved 5 July 2010 from <http://www.uconnucedd.org/projects/mind_the_gap/resources/Final%20Report_Mind%20the%20Gap.pdf>.
- Chisena, MP 2008, *Train-to-platform gap mitigator*, US Patent 7913628.
- ClearSy, SE 2007, *CACOLAC system: Automatic gap filler control device*, retrieved from <http://www.Fersil-railway.Com/dl/systeme_cacolac_en.Pdf>.
- ClearSy, SE 2010, *The COPP system device to open and close the platform screen doors*, retrieved 10 November 2010 from <<http://www.Fersil-railway.Com/dl/systeme-copp-en.Pdf>>.
- Commonwealth of Australia 2002, *Disability Standards for Accessible Public Transport 2002*, Australia.
- Drago, JJ 2008, *Train car compensator for platform gap spacing*, US Patent 20080134930 A1.
- Federal Railroad Administration (FRA) 2007, *FRA approach to managing gap safety*, Federal Railroad Administration, USA.
- Fullerton, K 2005, *Glidelok ramp*, Fresh Innovators 2005, Australia, retrieved 28 August 2010 from <<http://www.scienceinpublic.com/freshinnovators/2005/Kevin/kevinfullerton.htm>>.
- Hanrahan, PJ, Keegan, EK & Goffe, AT 1995, *Platform edge warning ramp*, US Patent 5444885 A.
- Klohn, H 1996, *Retractable station platform extension*, US Patent 5517921 A.
- Lecomte, T, Servat, T & Pouzancre, G 2010, *Formal methods in safety-critical railway systems*, ClearSy, retrieved 10 December 2010 from <http://www.Fersil-railway.Com/presse/formal_methods_in_safety_critical_railway_systems.Pdf>.
- Lee, WY 2008, *Safety gap fillers for railway platforms*, WO Patent 2008020690 A3.
- Lomberty, M, Korver, F, Launay, B & Barbe, F 2010, *Device for bridging a gap between a platform and a rail vehicle*, US Patent 20100058949 A1. Morlok, EK 2001, *The need for a new commuter car entranceway design for mixed high and low level platforms*, Annual Meeting of the Transportation Research Board, Washington DC, January 2002.
- Muller, RJ 1998, *Railway platform gap filler*, WO Patent 1998046465 A1.
- Rickert, T 2010, *Technical and operational challenges to inclusive Bus Rapid Transit: a guide for practitioners*, World Bank and TFESSD – Disability Window, Norway and Finland.
- The Rail Vehicle Accessibility (Non-Interoperable Rail System) Regulations 2010, Disabled Persons Transport, No. 432, 2010, Europe.

Vincent-Genod, B 2003, *Apparatus for reducing gaps between a platform and a guided vehicle*, US Patent 20030070576 A1.

Westinghouse, 2010, *Platform screen door – gap filler*, retrieved from
<<http://www.Platformscreendoors.Com/media/documents/gapfillerbrochure.Pdf>>.

Winkelmann, U & Hug, R 2010, *Gap-bridging device for train platforms*, WO Patent 2008040138 A1.

Yamaguchi, H, Maruyama, A, Takahashi, T & Mizobuchi, T 2001, *Step apparatus for platform*, US Patent 20010042489 A1.

Appendix 1 – Ranking based on cost

Ranking	Score/20	Solution	Ref sec
1.0	15.0	Corrugated platform edge	3.2.11
1.0	15.0	Safety gap filler	3.1.9
2.0	12.5	Glidelok ramp	3.2.9
2.0	12.5	Matangi on-board ramp	3.2.8
3.0	12.0	Platform gap filler	3.1.4
4.0	11.5	Rubberised on-board gap filler	3.2.5
4.0	11.5	Westinghouse platform screen door gap filler	3.2.7
5.0	11.0	Railway platform gap filler	3.1.4
6.0	10.5	Gap-bridging device for train platforms	3.1.5
6.0	10.5	Step apparatus for platform	3.1.3
7.0	10.0	Train car compensator	3.1.7
7.0	10.0	Platform edge warning ramp	3.1.1
8.0	9.0	Automatic gap filler	3.1.6
8.0	9.0	Interchangeable step design	3.2.10
9.0	8.5	Retractable station platform extension	3.1.10
9.0	8.5	Automatic gap filler	3.2.3
10.0	8.0	Movable platform edge	3.2.2
11.0	6.5	Platform edge extender	3.2.1
12.0	5.0	Train-to-platform gap mitigator	3.1.2
13.0	4.5	Gap-bridging device	3.1.8

Appendix 2 – Ranking based on implementation

Ranking	Score/20	Solution	Ref sec
1.0	18.0	Corrugated platform edge	3.2.11
1.0	18.0	Safety gap filler	3.1.9
2.0	16.0	Rubberised on-board gap filler	3.2.5
3.0	14.0	Platform gap filler	3.2.4
3.0	14.0	Railway platform gap filler	3.1.4
4.0	11.0	Glidelok ramp	3.2.9
4.0	11.0	Retractable station platform extension	3.1.10
4.0	11.0	Automatic gap filler	3.1.6
4.0	11.0	Gap-bridging device for train platforms	3.1.5
4.0	11.0	Matangi on-board ramp	3.2.8
5.0	10.0	Step apparatus for platform	3.1.3
6.0	9.0	Westinghouse platform screen door gap filler	3.2.7
6.0	9.0	Train car compensator	3.1.7
7.0	7.0	Platform edge warning ramp	3.1.1
7.0	7.0	Movable platform edge	3.2.2
8.0	3.0	Train-to-platform gap mitigator	3.1.2
8.0	3.0	Automatic gap filler	3.2.3
8.0	3.0	Gap-bridging device	3.2.8
9.0	2.0	Interchangeable step design	3.2.10
9.0	2.0	Platform edge extender	3.2.1

Appendix 3 – Ranking based on applicability

Ranking	Score/40	Solution	Ref sec
1.0	40.0	Matangi on-board ramp	3.2.8
1.0	40.0	Glidelok ramp	3.2.9
1.0	40.0	Train-to-platform gap mitigator	3.1.2
1.0	40.0	Interchangeable step design	3.2.10
2.0	33.3	Step apparatus for platform	3.1.3
3.0	26.7	Railway platform gap filler	3.1.4
3.0	26.7	Automatic gap filler	3.1.6
3.0	26.7	Westinghouse platform screen door gap filler	3.2.7
3.0	26.7	Platform edge warning ramp	3.1.1
3.0	26.7	Movable platform edge	3.2.2
3.0	26.7	Automatic gap filler	3.2.3
3.0	26.7	Gap-bridging device	3.1.8
3.0	26.7	Platform edge extender	3.2.1
4.0	20.0	Safety gap filler	3.1.9
4.0	20.0	Gap-bridging device for train platforms	3.1.5
5.0	13.3	Corrugated platform edge	3.2.11
5.0	13.3	Rubberised on-board gap filler	3.2.5
5.0	13.3	Platform gap filler	3.2.4
5.0	13.3	Retractable station platform extension	3.1.10
5.0	13.3	Train car compensator	3.1.7

Appendix 4 – Ranking based on operations

Ranking	Score/40	Solution	Ref sec
1.0	16.0	Platform edge warning ramp	3.1.1
1.0	16.0	Corrugated platform edge	3.2.11
1.0	16.0	Rubberised on-board gap filler	3.2.5
1.0	16.0	Platform gap filler	3.2.4
2.0	14.7	Safety gap filler	3.1.9
3.0	14.0	Glidelok ramp	3.2.9
4.0	12.7	Interchangeable step design	3.2.10
4.0	12.7	Retractable station platform extension	3.1.10
5.0	11.3	Train-to-platform gap mitigator	3.1.2
5.0	11.3	Railway platform gap filler	3.1.4
5.0	11.3	Automatic gap filler	3.1.6
5.0	11.3	Movable platform edge	3.2.2
5.0	11.3	Movable platform	3.2.1
6.0	10.0	Westinghouse platform screen door gap filler	3.2.7
6.0	10.0	Automatic gap filler	3.2.3
7.0	9.3	Gap-bridging device	3.1.8
8.0	8.7	Step apparatus for platform	3.1.3
8.0	8.7	Gap-bridging device for train platforms	3.1.5
8.0	8.7	Train car compensator	3.1.7
9.0	4.0	Matangi on-board ramp	3.2.8

Appendix 5 – Overall ranking

Ranking	Score/40	Solution	Ref sec
1.0	77.5	Glidelok ramp	3.2.9
2.0	67.7	Safety gap filler	3.1.9
3.0	67.5	Matangi on-board ramp	3.2.8
4.0	63.7	Interchangeable step design	3.2.10
5.0	63.0	Railway platform gap filler	3.1.4
6.0	62.5	Step apparatus for platform	3.1.3
7.0	62.3	Corrugated platform edge	3.2.11
8.0	59.7	Platform edge warning ramp	3.1.1
9.0	59.3	Train-to-platform gap mitigator	3.1.2
10.0	58.0	Automatic gap filler	3.1.6
11.0	57.2	Westinghouse platform screen door gap filler	3.2.7
12.0	56.8	Rubberised on-board gap filler	3.2.5
13.0	55.3	Platform gap filler	3.2.4
14.0	53.0	Movable platform edge	3.2.2
15.0	50.2	Gap-bridging device for train platforms	3.1.5
16.0	48.2	Automatic gap filler	3.2.3
17.0	46.5	Platform edge extender	3.2.1
18.0	45.5	Retractable station platform extension	3.1.10
19.0	43.5	Gap-bridging device	3.1.8
20.0	41.0	Train car compensator	3.1.7